



E-LINE CCR

MANUAL

www.eaeelectric.com

EAE GROUP IN NUMBERS



Since 1973

EAE Group of Companies started its journey in the electrical sector in 1973 with the establishment of EAE Elektrik. Since its founding, EAE has grown rapidly, expanding its production and areas of operation by incorporating EAE Lighting in 1983, EAE Machinery in 1996, EAE Electrotechnics in 2004, and EAE Technology in 2009.

EAE carries out its production activities in accordance with ISO 9001 Quality Management, ISO 14001 Environmental Management, ISO 14064-1 Greenhouse Gas Management System, ISO 45001 Occupational Health and Safety Management, ISO 10002 Customer Satisfaction Management, ISO 50001 Energy Management System, and ISO 27001 Information Security Management System standards.



50+

Years Experience



7

Active Factories



360.000m²

Enclosed Space



3

R&D Centers



150+

Countries Exported To

CONTENTS

►► E-LINE CCR-II

Introduction	2
General.....	3
Unloading, Handling and Storage of Products	4
Handling & Storage	5
Joint Structure.....	6
Energizing	7
Project Design	8
Horizontal & Vertical CCR Busway Applications	9
Fixing Elements	10-15
Equipment Used	16
Measuring a Special Length	17
Preparation of CCR Joint Flex-Comp	18-19
Installation / Horizontal	20-21
Installation / Edgewise	22-23
Installation / Vertical.....	24-25
Preparation of Joint Casting Material.....	26
CCR B10 Feeder Box Installation Manual	27
CCR B10 Feeder Box Installation Manual / Edgewise.....	28
Electrical site-tests	29
Annex A Site Joint Test Instruction.....	30-31
Maintenance.....	32
EAE Electrical Site Test Report	33-34
Declaration	35
Certificates	36
Product Overview	37-38

E-LINE CCR MANUAL

►► Introduction



Dear Customer

EAE Elektrik A.S. Products are designed to provide the maximum benefit in efficiency and service. Our products are manufactured in accordance with IEC standards and EAE is quality assured to ISO 9001 standards in their modern production plants in Istanbul .

The components that you have purchased are manufactured by a completely environment conscious, that is ISO 14001 certified.

These instructions should be read carefully and acted upon before taking delivery of equipment on site.

Handling, installation and operation of busbar systems should be carried out only by skilled, trained and authorized personnel using all associated equipment such as rubber gloves, helmet, safety glasses or face shields and flash resistant clothing in accordance with established safety practices.

The busbar system's successful operation depends on correct handling, installation, operation and maintenance. Improper installation may cause personal injury and the failure of the busbar system and damage to other property.



E-LINE CCR MANUAL

►► General



BUSBARS SHOULD NOT BE IN TOUCH WITH ANY LIQUID MATERIAL BEFORE ASSEMBLING.

BUSBARS THAT ARE NOT ASSEMBLED COMPLETELY HAVE NO PROTECTION AGAINST TO WATER.

BUSBARS ARE DESIGNED AND TESTED IN ACCORDANCE WITH IEC 61439-6 TO OPERATE RELIABLY BETWEEN -25 °C AND +40 °C.

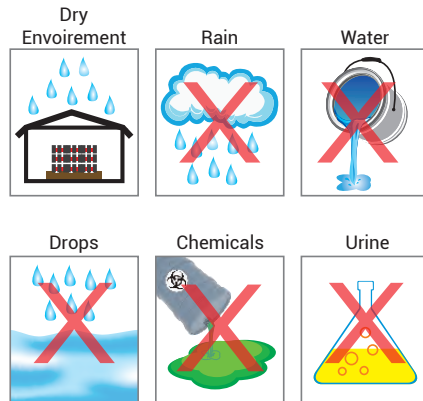

IT IS RECOMMENDED TO USE WITH A CANOPY IN OUTDOOR ENVIRONMENTS OF 40°C AND ABOVE.

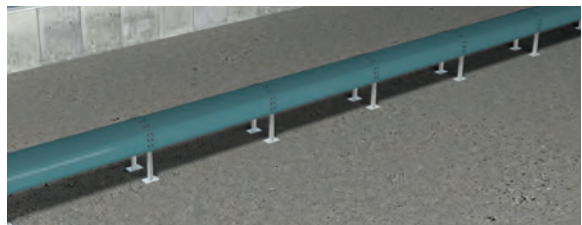

E-LINE CCR MANUAL



►► Unloading, Handling and Storage of Products

Introduction:

This installation manual provides the necessary instructions for the safe, efficient, and proper handling and installation of cast resin busbar systems.

It must be read carefully before any work is carried out. All steps and instructions should be followed strictly to avoid personal injury, equipment damage, and installation errors.

Unloading:

- A suitable forklift is the safest and most efficient method for unloading products from the container or truck at the worksite.
- Unload carefully to avoid harm or damage to the busbar lengths and associated components.
- Position pallets on stable ground immediately after unloading.

Inspection Upon Receipt:

- Verify the number of pallets and the condition of the busbar lengths against the Packing List.
- Check dimensions and inspect all items for possible transit damage.
- Report any missing or damaged items immediately to the Insurance Company and the local EAE representative for corrective action with proper documentation.

Storage:

- Store all products in a dry, clean, and covered environment.
- Resin and hardener (joint casting materials) must be stored between 5°C and 25°C and protected from direct sunlight.
- When stacking busbar lengths:
 - Use wooden spacers every 1.5 m between layers.
 - Do not stack more than 5 modules horizontally.

Handling and Lifting:

- Do not handle busbar modules using steel ropes or hooks as these may cause damage.
- For lifting:
 - Insert metal rods through the designated lifting holes at each end of the module.
 - Use lifting straps/slings to lift and move the modules safely.
 - Short modules may be lifted with a single strap only if the load remains balanced.
- Ensure the load is always stable and secure during movement to prevent twisting or surface damage.

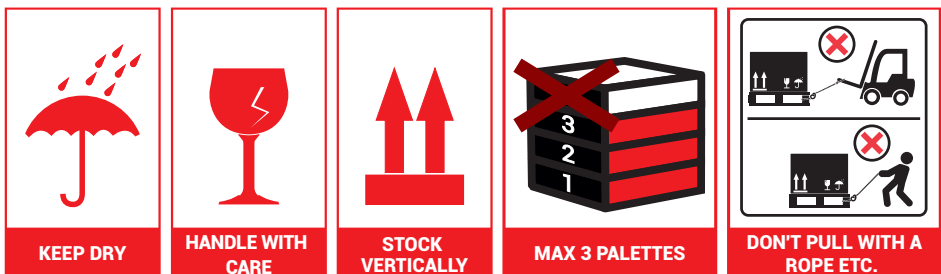
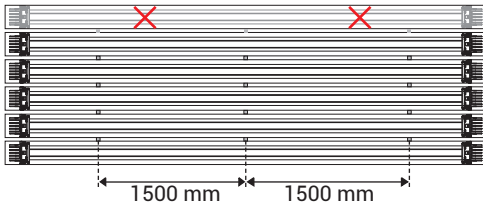

E-LINE CCR MANUAL

►► Handling & Storage



Pre-Cast Electrical Testing of Join (Junctrue) Areas:

- The final check form provided must be completed for each joint installed.
- Perform a Megger test after each joint assembly to confirm correct insulation and ensure no defects are present.
- To avoid damage to transformers, terminals, MCCBs, or other connected equipment, disconnect or isolate them before testing.
- After each insulation test, fully discharge the system to earth.
- After completing all electrical tests, reconnect terminals, MCCBs, fuses, and associated equipment.
- Submit the completed test record form to the EAE representative.
- Additionally, the Product Quality Approval Form (Form 186) must be completed and submitted for warranty validation.

Installation Guidelines:

- Read the handling instructions on the pallet before lifting. Consider pallet weight when preparing lifting equipment.
- Hang and support the product only in the lifting configuration as shown in the Figure 1 manufacturer's instructions.
- Store resin and hardener according to the recommended method Figure 2.
- Mark the busbar route clearly before installation begins.
- Start installation from a single point (preferably the panel) and progress sequentially to the last module.
- Before casting a joint:
 - Perform a Megger test.
 - Ensure the test result indicates infinite resistance.
 - Only then proceed with the casting process.
- Do not use expired joint casting agents.

Safety & Quality Notes:

- Handle all busbar lengths and modules with care to avoid internal component damage.
- Ensure correct alignment during assembly to maintain performance and system reliability.
- Follow all site safety requirements, including PPE and work permits where applicable.

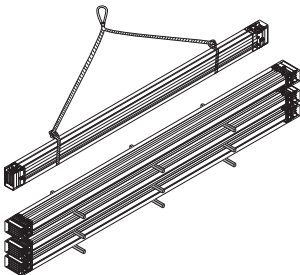

Figure 1

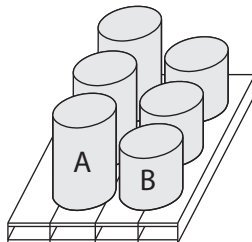

Figure 2

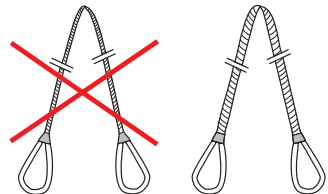
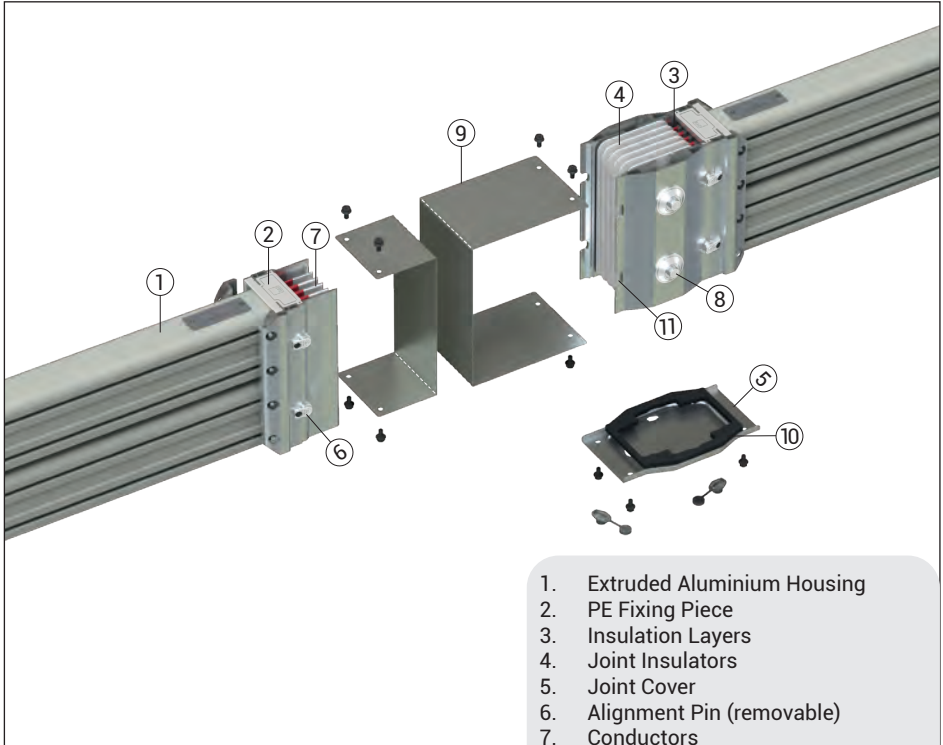

Figure 3

E-LINE CCR MANUAL

►► Joint Structure



- 1. Extruded Aluminium Housing
- 2. PE Fixing Piece
- 3. Insulation Layers
- 4. Joint Insulators
- 5. Joint Cover
- 6. Alignment Pin (removable)
- 7. Conductors
- 8. Nut Locking Piece
- 9. Cover plates
- 10. Joint Cover Gasket
- 11. Alignment Pin Slot

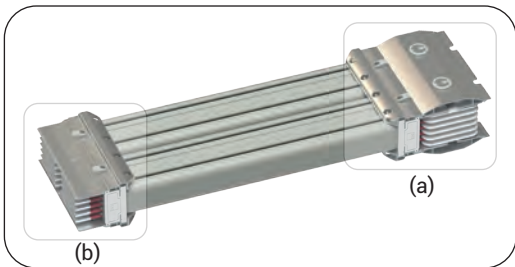

CCR busbars are supplied in standard 3-meter lengths, however custom lengths can be manufactured to suit project requirements. Each module is provided with a block joint connection at one end, while the opposite end is supplied without a block joint.

▶ Before Energizing

Ensure all busbar ratings, routing paths, and support systems are installed in accordance with the final as built/isometric drawings.

Inspect the entire busbar system to confirm it is clean, secure, and free from damage.

Loose or contaminated joints can increase electrical resistance and may cause overheating.

Do not use blowers or compressed air, as this may force dust into joints, tap-off boxes, or circuit breakers.

If cleaning is required, use a soft brush, vacuum cleaner, or clean lint-free cloths.

Confirm that all joints are tightened to the specified torque values and properly marked after tightening. Ensure locking plates are installed correctly at every joint.

Isolate the busbar runs by disconnecting all incoming and outgoing electrical connections.

Perform an insulation resistance test (Megger Test) using a 1000 V DC insulation tester to verify system integrity.

Conduct the test between:

Phase to Phase

Phase to Neutral

Phase to Earth

Maintain permanent records of the test readings.

If any reading is below 1 MΩ, investigate and rectify the cause before proceeding.

Confirm the phase sequence of the busbar system matches that of the transformers, switchboards, meters, and associated equipment before reconnecting all terminations.

E-LINE CCR MANUAL

►► Project Design

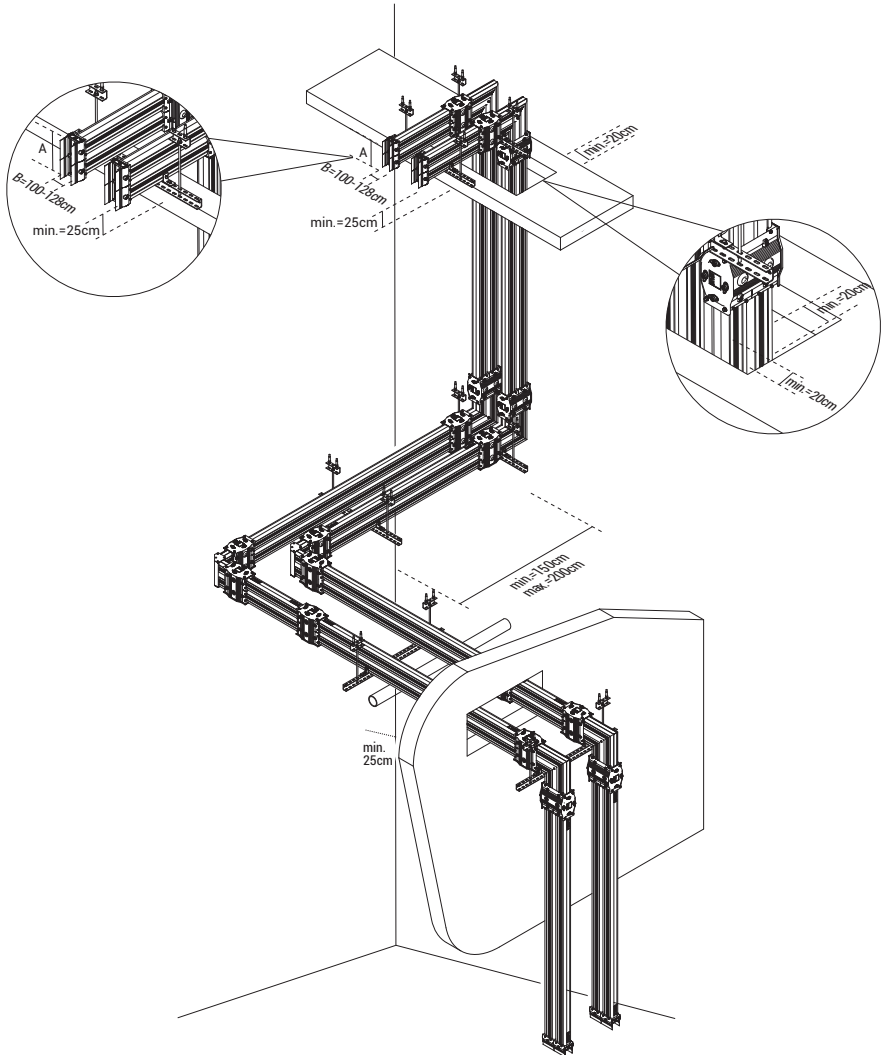

⚠ In multipath busbars in high-rise vertical shaft applications; Due to floor heights, floor thickness and product tolerances, the window or additional point alignments on the upper floors may not be the same. In order for the Tap off boxes to be aligned and the joint point not to coincide with the floor transitions, the assembly should be continued by making measurements on each floor.

■ EAE is not responsible for the potential risks that may occur in cases where the products in our catalogue are used outside of the standard phase sequences as shown in the catalogue.

E-LINE CCR MANUAL

►► Horizontal & Vertical CCR Busbar Applications



Figure 1 - Edgewise Application

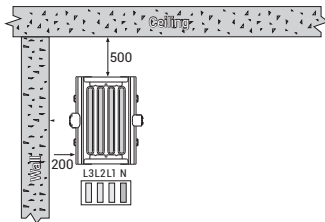

Figure 2 - Edgewise Application

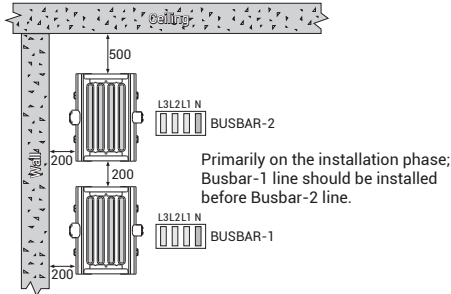

Figure 3 - Flatwise Application

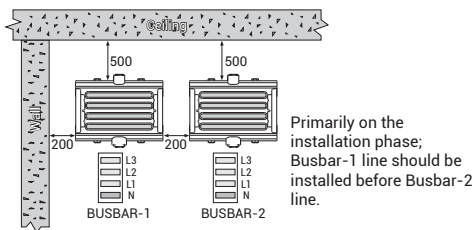

Figure 4 - Crossing Under A Beam On Edgewise Application

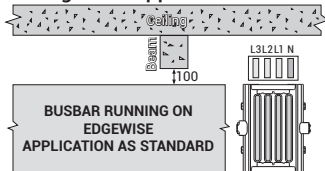

Figure 5 - Crossing Under A Beam On Flatwise Application

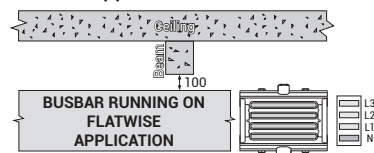

Figure 6 - Sample Wall Crossing With Fire Barrier

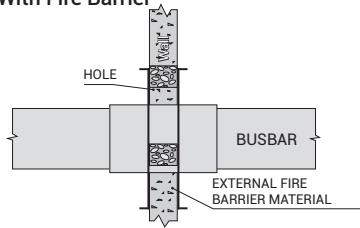

Figure 7 - Standard Wall Crossing

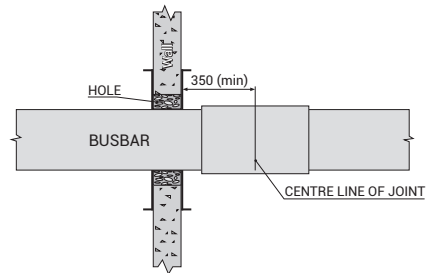

Figure 8 - Edgewise application in gallery

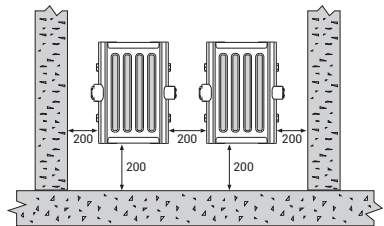
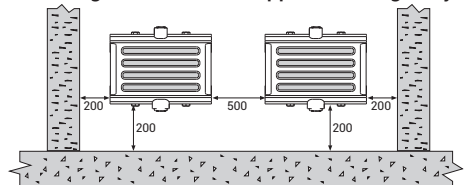

Figure 9 - Flatwise application in gallery



Attention!

- For correct installation, the dimension from the busbar to the ceiling should not be less than 500mm
- The joint should be not come across to Beams.
- The dimensions given above are minimum values.
- All dimensions are given in mm.

E-LINE CCR MANUAL

►► Fixing Elements



► Vertical Shaft Type Carriers

CCR Vertical Riser Fixing Unit

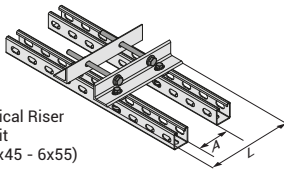
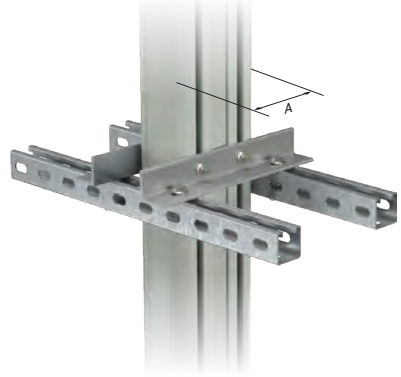

CCR-Vertical Riser Fixing Unit (6x40 - 6x45 - 6x55)

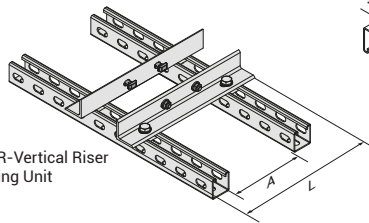

CCR-Vertical Riser Fixing Unit

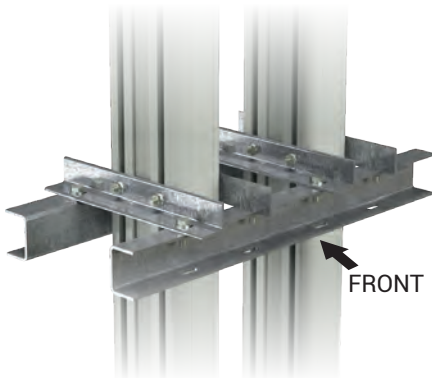
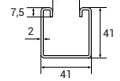
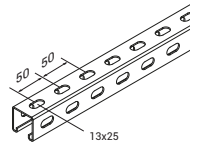

Vertical Riser Application Sample Order Hanging (Special to project)

E-LINE CCR MANUAL

►► Fixing Elements



► Ceiling Type Supports

CCR-UT Two-Way For Edgewise Application To NPI Channel

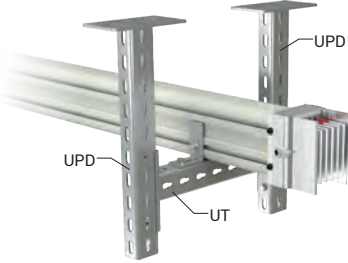

► Floor Type Supports

CCR-UT Two-Way For Edgewise Application To NPI Channel

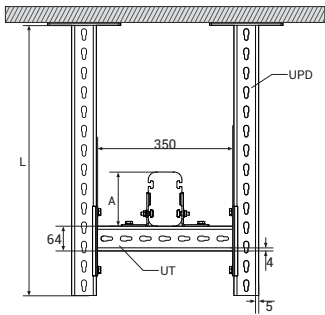
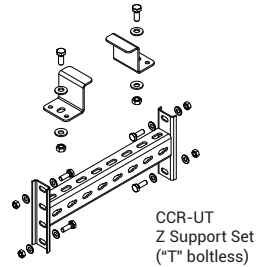
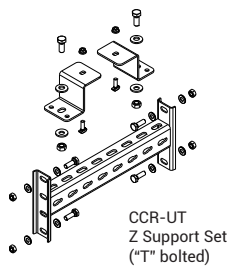
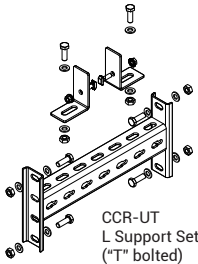
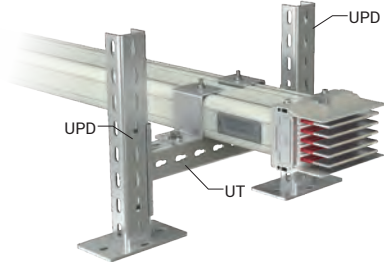

⚠ When selecting an UPD product, please keep in mind to select the UPD product suitable to the Busbar A dimension.

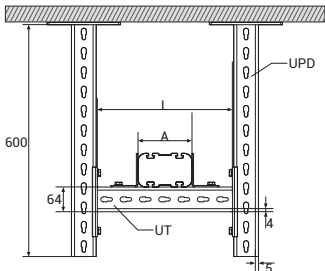
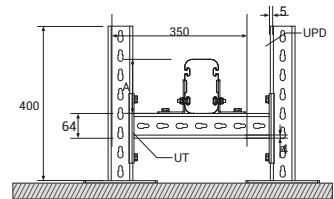

⚠ When choosing CCR-UT Support Set, appropriate CCR-UT Support Set should be selected according to Busbar size.

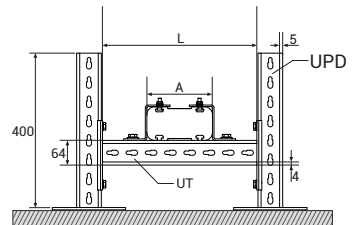

■ *Flatwise Application is supplied for only on special conditions.

■ Please call us for non-standard dimensions.

E-LINE CCR MANUAL

►► Fixing Elements



► Heavy Duty Supports (U)

Hot Dip Galvanized After Fabrication (TS EN ISO 1461)

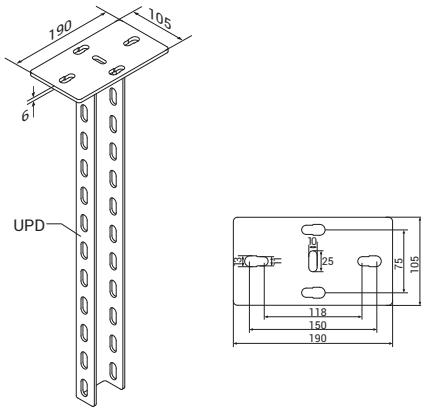

⚠ When selecting an UPD product, please keep in mind to select the UPD product suitable to the Busbar A dimension.

► CCR-UT Suspension Assembly

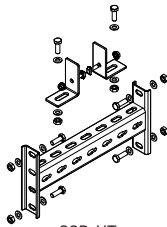

CCR-UT
Support Set
("T" bolted)

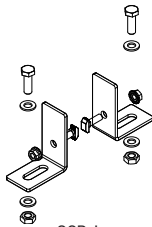

CCR-L
Support Set
("T" bolted)

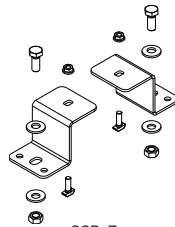

CCR-Z
Support Set
("T" bolted)

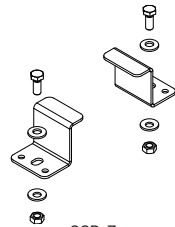

CCR-Z
Support Set
("T" boltless)

⚠ When choosing CCR-UT Suspension Set, appropriate CCR-UT Suspension Set should be selected according to Busbar size.

■ Please check our Suspension Systems (A-A) Catalogue to see our alternative solutions for suspension types.

■ The dimensions given above are minimum values.

■ Please call us for non-standard components.

■ All measures are given in mm.

E-LINE CCR MANUAL



►► Fixing Elements

► Ceiling Type Supports

CCR-IDY Two-Way For Edgewise Application To NPI Channel

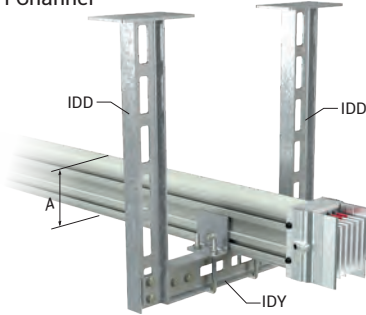

► Floor Type Supports

CCR-IDY Two-Way For Edgewise Application To NPI Channel

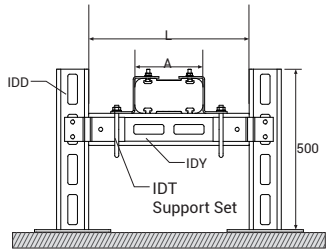
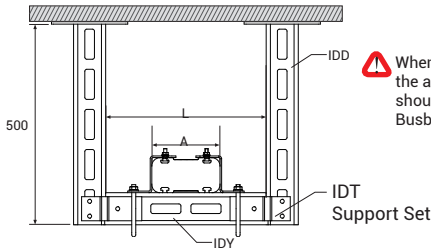
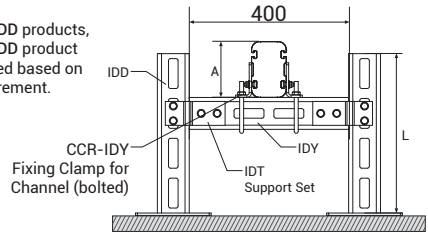
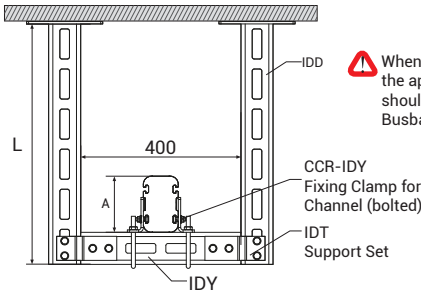
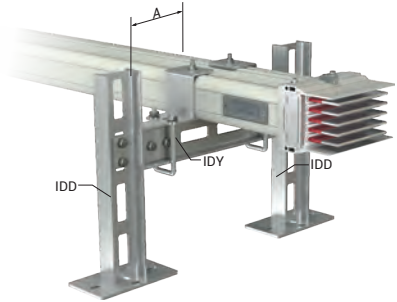

► Supports

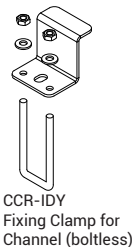
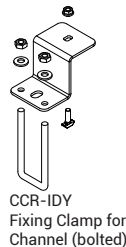
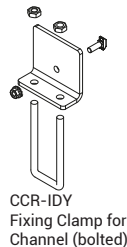
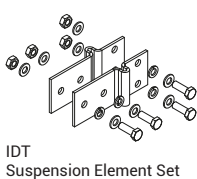

■ Please check our Suspension Systems (A-A) Catalogue to see our alternative solutions for suspension types.

■ The dimensions given above are minimum values.

■ Please call us for non-standard components.

■ All measures are given in mm.

E-LINE CCR MANUAL

►► Fixing Elements



► IDD Type Supports

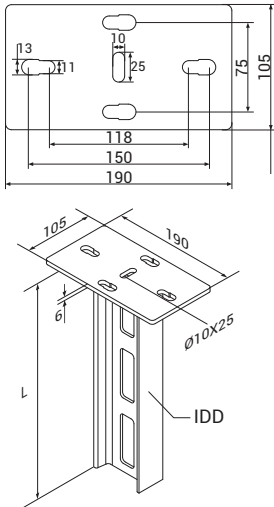

When selecting IDD products, the appropriate IDD product should be selected based on Busbar A measurement.

► IDY Type Supports

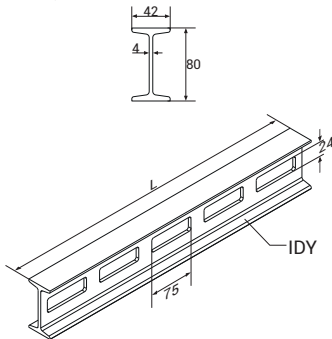

When selecting IDY products, the appropriate IDY product should be selected based on Busbar A measurement.

■ Please check our Suspension Systems (A-A) Catalogue to see our alternative solutions for suspension types.

■ The dimensions given above are minimum values.

■ Please call us for non-standard components.

■ All measures are given in mm.

E-LINE CCR MANUAL

►► Fixing Elements



► Ceiling Type Supports

CCR-Threaded Rod Two-Way For Edgewise Application To NPI Channel

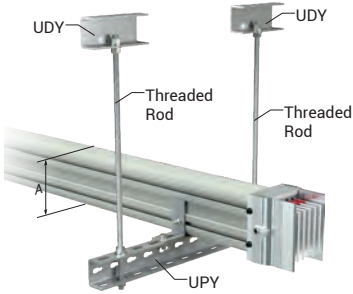

CCR-Threaded Rod Two-Way For Flatwise Application To NPI Channel

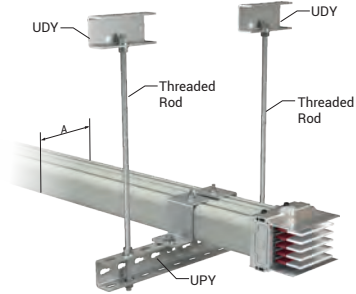

► Supports

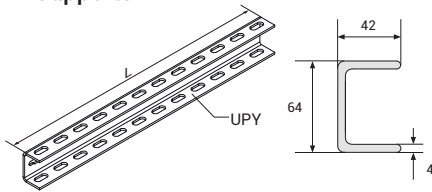

CCR-L Suspension Set

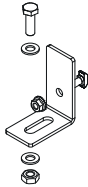

CCR-Z Support Set

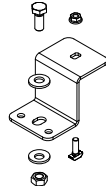

CCR-Z Support Set

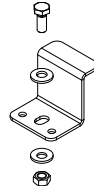

Fixing Elements

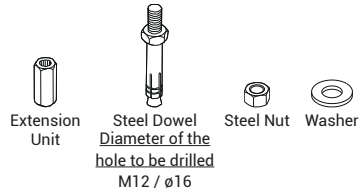
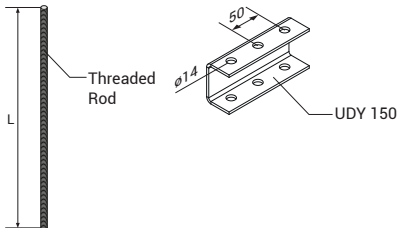

■ Please check our Suspension Systems (A-A) Catalogue to see our alternative solutions for suspension types.

■ The dimensions given above are minimum values.

■ Please call us for non-standard components.

■ All measures are given in mm.

E-LINE CCR MANUAL

►► Equipment Used

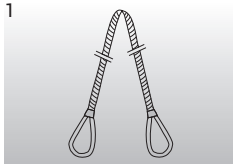

Fabric Crane Ropes

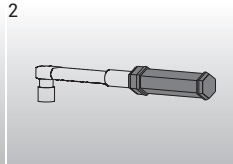

Torque Wrench

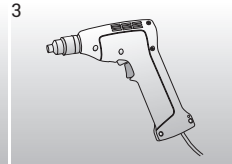

Hot Air Blower

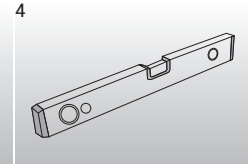

Spirit Level

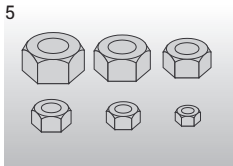

Nut Set

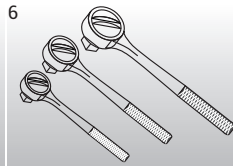

Socket Set

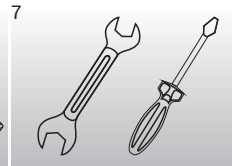

Wrench, Screwdriver



Lifting Device
(forklift truck, crane, hoist
etc.)

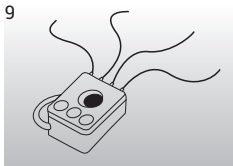

Megger Device

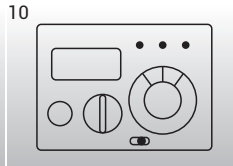

Dielectric Test Device
5 kV DC



Scaffold



Mixer



Protective
Clothes,
Gloves, Goggles

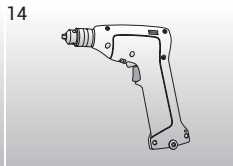

Drill

E-LINE CCR MANUAL

►► Measuring a Special Length



After installation of standard busbar 3m lengths, you will be in need of special lengths which are smaller than 3m. The minimum length for these special elements can be 450mm. Please measure the lengths of these modules as shown below.

Length A is measured between housing of 2 busbars in mm. A. The special length is calculated by deducting 290mm from this measured length.

$$X = A - 290\text{mm}$$

X = Length of Special Busbar

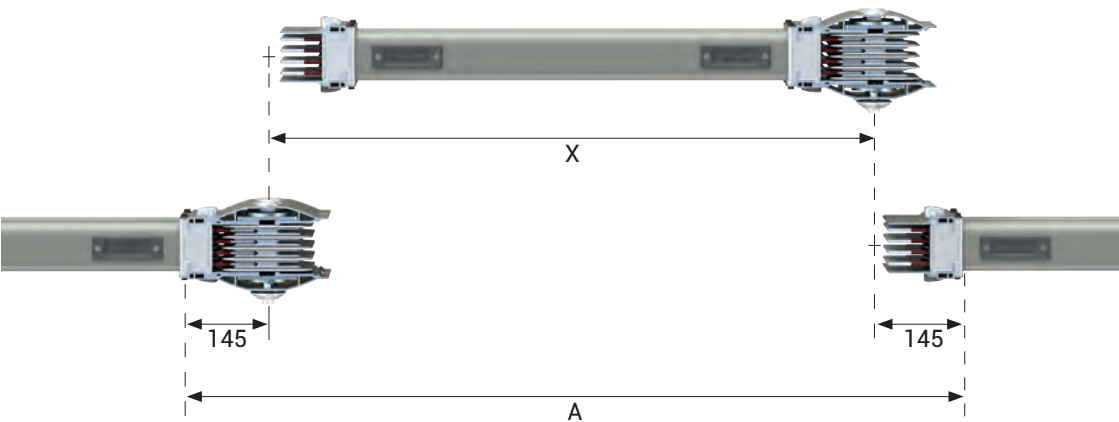

E-LINE CCR MANUAL

►► Preparation of CCR Flex-Comp



► Preparation of Flex-Comp

The insulation resistance (Megger) test must be completed and verified before performing the joint casting.

If Flex-Comp (A) and Flex-Comp (B) have been stored in a cold environment, they should be placed in a warm area (above 20°C) at least one day prior to casting.

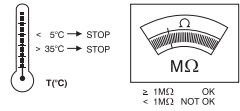

The ambient temperature during casting must be maintained within the range:
 $5^{\circ}\text{C} < T_{\text{casting}} < 35^{\circ}\text{C}$

Depending on environmental conditions, the curing time may exceed 48 hours. After casting, ensure the block joint area is properly covered to prevent contact with water, dust, or any liquids during the curing period.

Preparation of Flex-Comp



Flex-Comp (A)



Flex-Comp (B)



Flex-Comp (A)
(1,75kg)

Flex-Comp (B)
(1,75kg)



Pour Flex-Comp (B) into Flex-Comp (A). One complete set is 3.5 kg. The required quantity of material for each joint depends on the busbar cross-section, as shown in the table next page. Determine the number of sets needed according to the total number of joints to be cast during the installation process.

Mix the combined material using a low-speed beater for 30 seconds to 1 minute, or until a uniform and homogeneous mixture is achieved.

E-LINE CCR MANUAL

►►Preparation of CCR Flex-Comp



Amount of Resin to be Used

CCRA - Al Conductor		CCRC - Cu Conductor		Conductor	3 Conductor (kg)	4 Conductor (kg)	4½ - 5 Conductor (kg)
Rated Current	Busbar Code	Rated Current	Busbar Code				
600	06	650	06	6x40	1,5	1,7	1,8
-	-	850	08	6x45	1,6	1,8	2,1
-	-	1000	10	6x55	1,6	1,9	1,9
800	09	1250	12	6x80	1,8	2,0	2,2
1000	10	-	-	6x95	1,9	2,2	2,4
1250	12	1600	16	6x110	2,0	2,3	2,5
-	-	2000	20	6x150	2,3	2,7	3,0
1600	16	-	-	6x160	2,4	2,8	3,1
2000	21	-	-	6x230	2,9	3,3	3,7
-	-	2500	25	2(6x80)	2,7	3,1	3,4
-	-	3200	32	2(6x110)	3,2	3,7	3,9
-	-	3400	34	2(6x125)	3,5	4,0	4,4
2500	25	-	-	2(6x130)	3,6	4,2	4,5
-	-	4000	40	2(6x140)	3,7	4,3	4,6
3000	31	-	-	2(6x160)	4,1	4,7	5,3
3300	33	4500	45	2(6x180)	4,6	5,1	5,7
3600	37	-	-	2(6x200)	4,8	5,5	6,1
4000	41	-	-	2(6x230)	5,1	5,8	6,3
4500	44	-	-	2(6x250)	5,2	5,9	6,4
-	-	5000	50	3(6x125)	4,9	5,6	6,1
-	-	5750	57	3(6x160)	5,8	6,6	7,3
5000	50	6300	63	3(6x180)	6,5	7,4	8,0
5400	54	-	-	3(6x200)	7,1	8,0	8,2

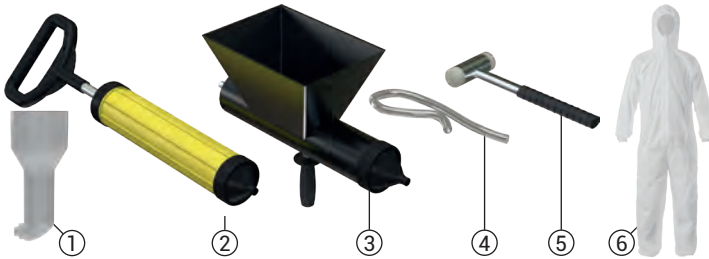

CCR Flex-Comp Mixer

Description	Order Code
CCR Flex-Comp Mixer	5002396



Casting Materials

No	Açıklama	Order Code
1	CCR Level Check Pipei	3271279
2	CCR Injection Pump	3254100
3	Flex-Comp Casting Apparatus	5003447
4	Flex-Comp Transparent Hose Set	5003607
5	CR Plastic Hammer	5000310
6	Disposable Protective Overall	5003622

E-LINE CCR MANUAL

►► Installation / Horizontal

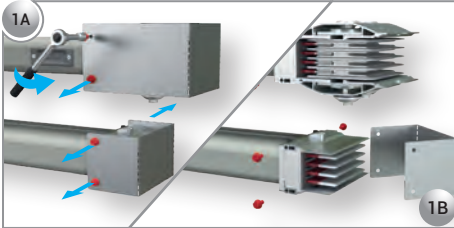

Remove the busbar protection covers by unscrewing the bolts



Remove the nut locking cover.

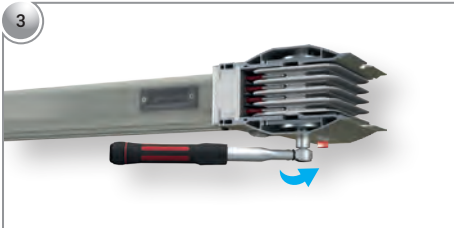

Loosen the block splice nuts.

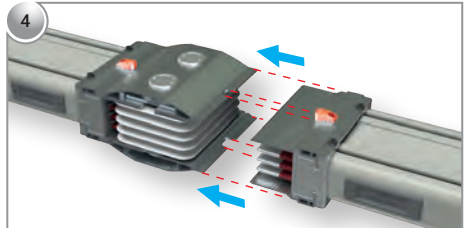

Verify the orientation and compatibility of the busbar sections and alignment components before assembly. Position the alignment components on top and connect the busbar lengths accordingly.

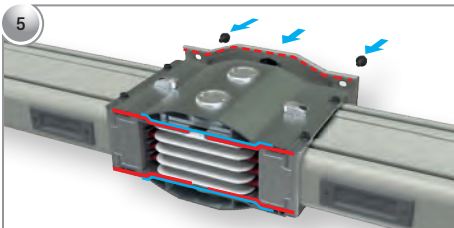

Install the block joint cover and tighten the bolts lightly. Adjust until the busbars are properly aligned in the slots.

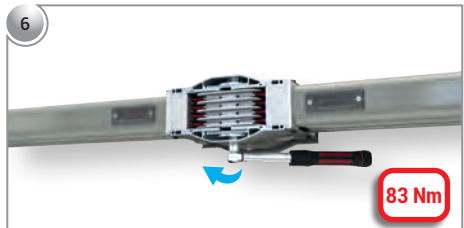

After verifying alignment, torque the block joint nuts to 83 Nm.

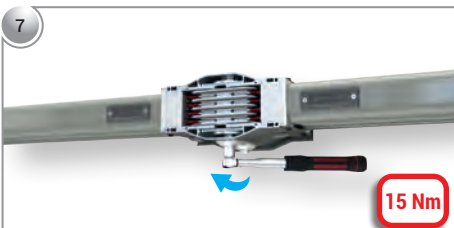

Reinstall the nut locking covers and torque with 15 Nm.

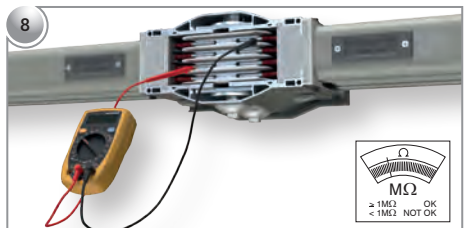

Perform an insulation resistance test between all phases at the installed block joint point.

E-LINE CCR MANUAL

►► Installation / Horizontal

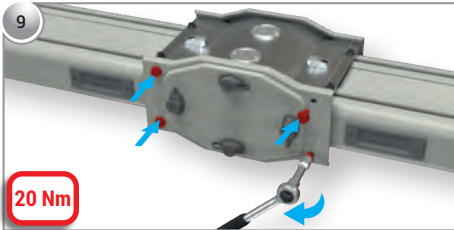

Install the second block joint cover and torque its bolts to 20 Nm.

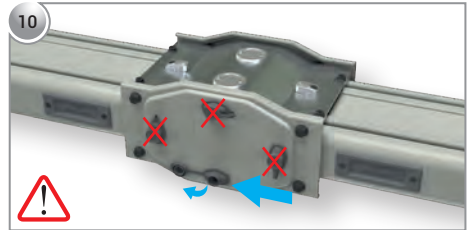

Remove the plastic cover from the casting area as shown in the visual.

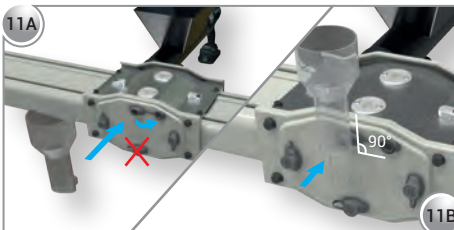

Open the plastic cover on the opposite side of the block joint to be cast, and install the CCR Block Joint Casting Level Control Plastic.

Attention: The level control plastic must be oriented 90° upwards.

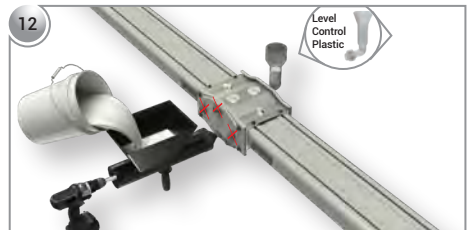

Inject the material through the filling hole as shown. Continue filling until Flex-Comp becomes visible in the level control plastic. **Attention:** Monitor the level in the control plastic and add more Flex-Comp if the level drops.



After the initial filling, gently tap the underside of the busbar block joint with a plastic mallet. If the Flex-Comp level in the level control plastic drops during tapping, continue adding Flex-Comp through the filling point specified in Step 12.

Attention: Continue refilling until the Flex-Comp level remains stable.

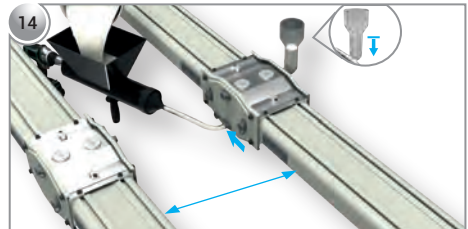

Use a transparent hose in confined spaces to complete the filling process through the indicated filling hole. Continue filling until Flex-Comp is visible inside the control plastic, and apply step 13.

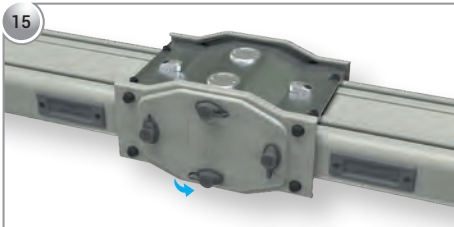

Once the injection process is complete, close the plastic cover and finalize the installation.

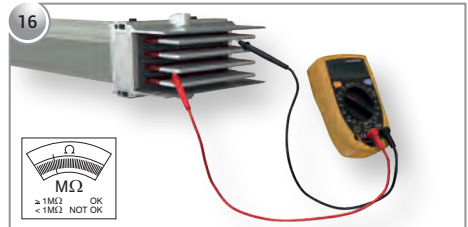

An insulation resistance test must be conducted at least 24 hours after the procedure is completed.

E-LINE CCR MANUAL

►► Installation / Edgewise

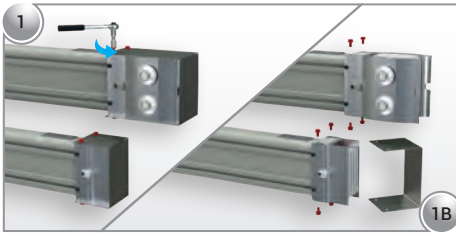

Remove the busbar protection covers by unscrewing the bolts.

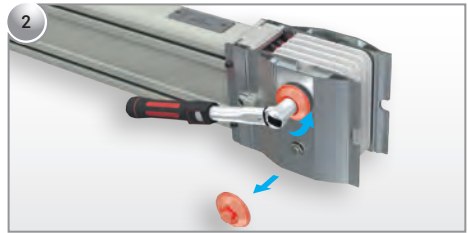

Remove the nut locking cover.



Loosen the block joint nuts.

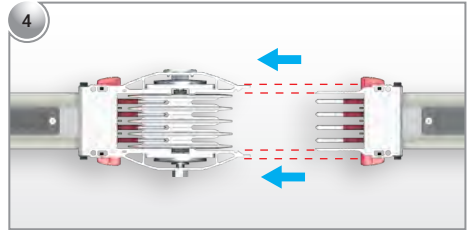

The adjacent busbar is assembled utilizing the alignment pins for correct orientation and alignment of parts. The small alignment pin goes to the small part and the large alignment pin goes to the large part.

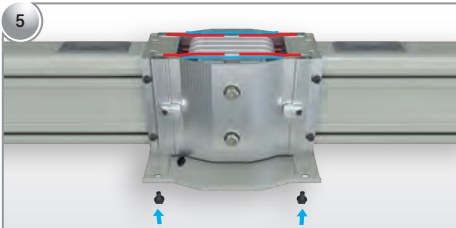

Install the lower block joint cover to align the busbars, tightening the cover bolts to a moderate torque. Adjust until the busbars fit perfectly into the alignment slots.

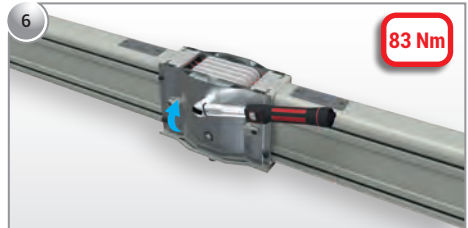

After verifying alignment, torque the block joint nuts to 83 Nm.

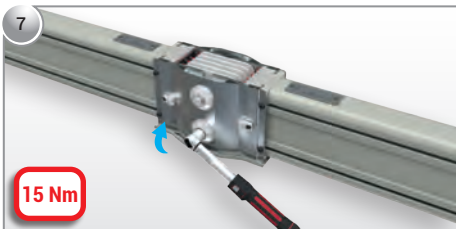

Reinstall the nut locking covers and torque with 15 Nm.

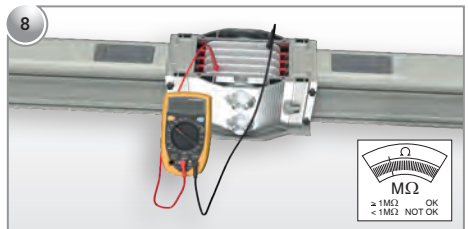

Perform an insulation resistance test between all phases at the installed block joint point

E-LINE CCR MANUAL

►► Installation / Edgewise

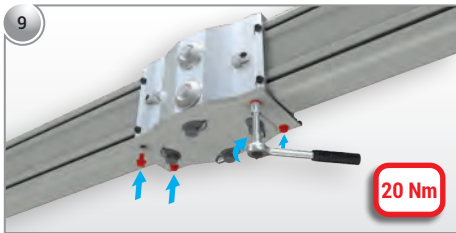

Torque the bolts of the lower block joint cover to 20 Nm.

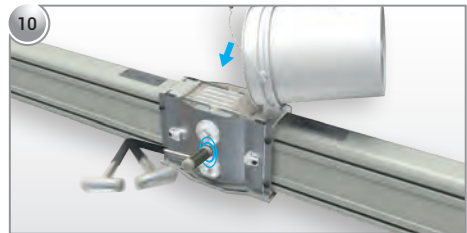

At the open end of the block joint cover, perform the Flex-Comp casting to the top level of the block joint. Apply vibration with a plastic mallet.

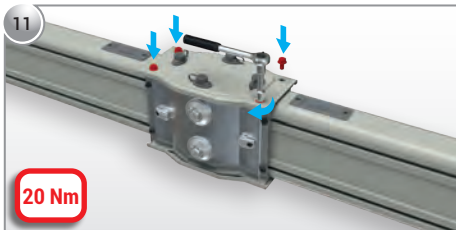

Install the top block joint cover and torque its bolts to 20 Nm.

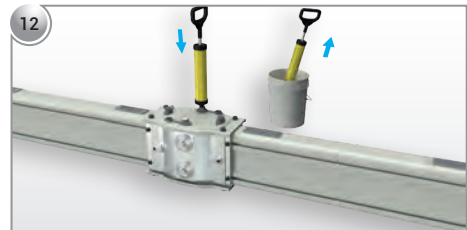

Ensure the injection piston is fitted to prevent leakage at the casting opening and inject Flex-Comp material into the block joint cavity using a lever. Continue injection until Flex-Comp is visible from the other end. Close the plastic cover and finalize the installation.

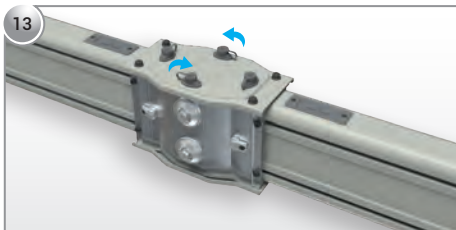

Once the injection process is complete, close the plastic cover and finalize the installation.



An insulation resistance test must be conducted at least 24 hours after the procedure is completed.

E-LINE CCR MANUAL

►► Installation / Vertical

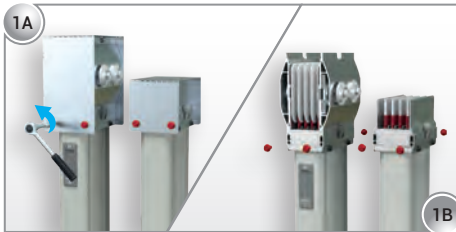

Remove the busbar protection covers by unscrewing the bolts

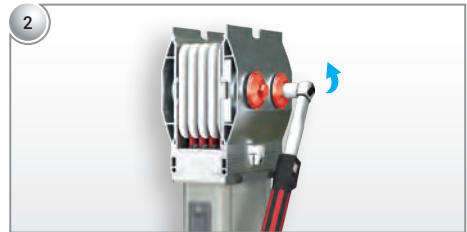

Remove the nut locking cover.

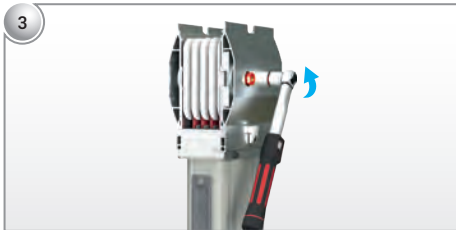

Loosen the block splice nuts.

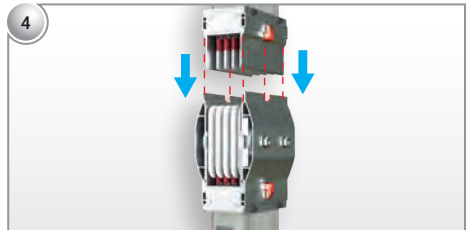

Verify the orientation and compatibility of the busbars and alignment components to be added. Connect the busbars with the small alignment components on top.

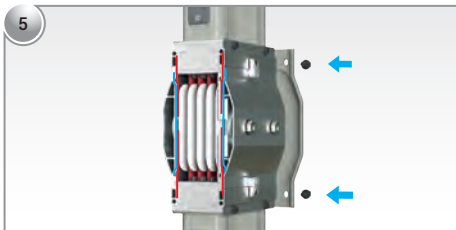

Install the block joint cover to align the busbars, tightening the cover bolts to a moderate torque. Adjust until the busbars fit perfectly into the alignment slots.



After verifying alignment, torque the block joint nuts to 83 Nm.

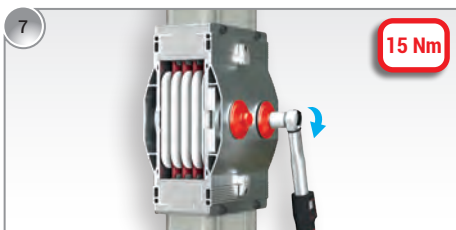

Reinstall the nut locking covers and torque with 15 Nm.



Perform an insulation resistance test between all phases at the installed block joint point.

E-LINE CCR MANUAL

►► Installation / Vertical

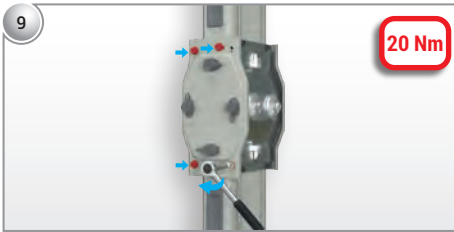

Install the other block joint cover and torque its bolts to 20 Nm.

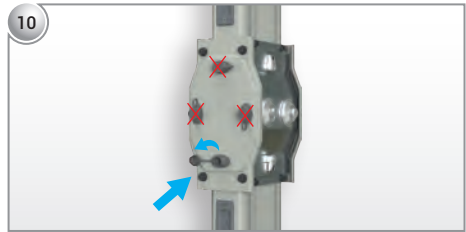

Remove the plastic cover from the casting area as shown in the visual.

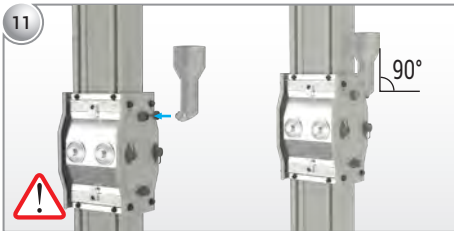

Open the plastic cover on the opposite side of the block joint to be cast, and install the CCR Block Joint Casting Level Control Plastic.

Attention: The level control plastic must be oriented 90° upwards.



Inject the material through the filling hole as shown. Continue filling until Flex-Comp becomes visible in the level control plastic. **Attention:** Monitor the level in the control plastic and add more Flex-Comp if the level drops.

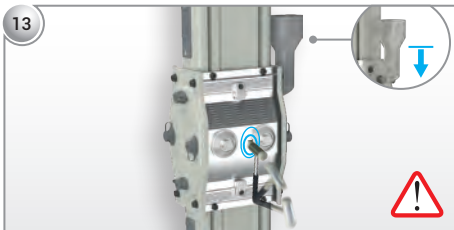

After the initial filling, tap the busbar block joint from underneath with a plastic mallet. If a drop in the Flex-Comp level is observed in the level control plastic during hammering, continue the Flex-Comp filling process through the plastic cap specified in step 12.

Attention: Refilling the process until the Flex-Comp level stabilizes.

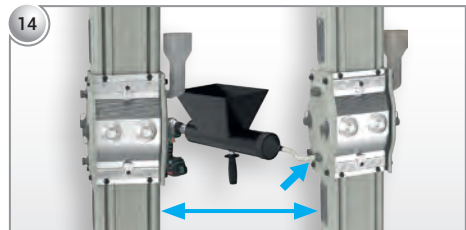

Use a transparent hose in confined spaces to complete the filling process through the indicated filling hole. Continue filling until Flex-Comp is visible inside the control plastic, and apply step 13.



Once the injection process is complete, close the plastic cover and finalize the installation.



An insulation resistance test must be conducted at least 24 hours after the procedure is completed.

E-LINE CCR MANUAL

►►Preparation of Joint Casting Material



Preparation of Cast Resin Mixture

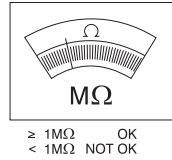
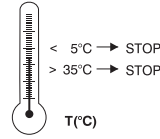
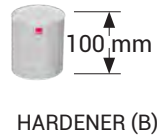
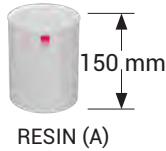

Filler removed from the plastic bucket and fillers have to be absolutely dry

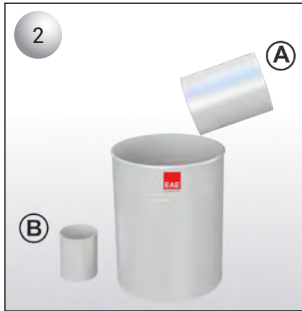

Resin and hardener are mixed in plastic bucket.

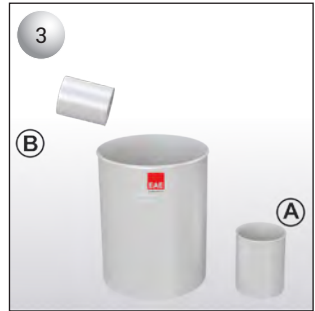

Mix resin and hardener thoroughly with stirrer at least 30-60 seconds.

Attention : Please not leave mixed Resin (A) and Hardener (B) for a long time to prevent overheat in bucket. You need to add filler in it. Between two steps (4-5) time period must be max 10 minutes.



Add fillers and mix until homogeneous; at least 2-3 minutes. Then application must be done within 15 minutes.

E-LINE CCR MANUAL

►► CCR B10 Feeder Box Installation Manual

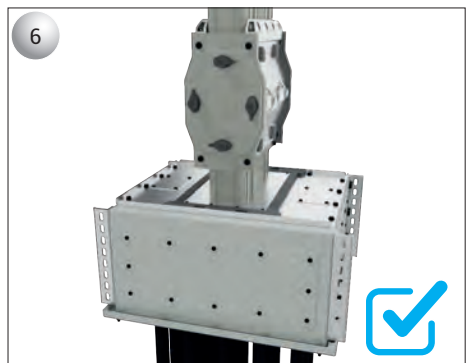
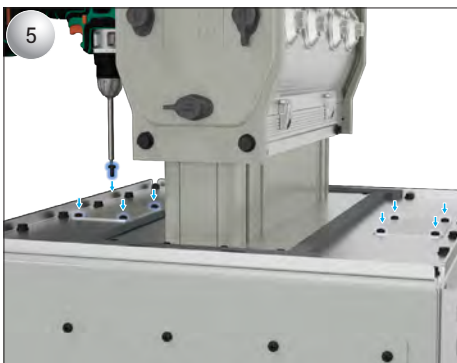
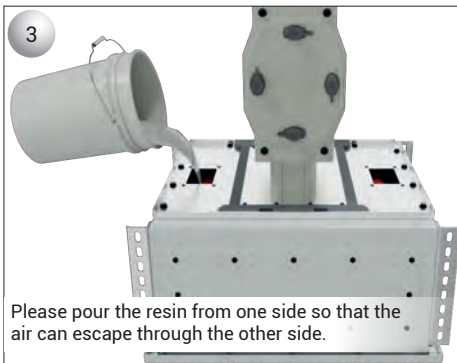
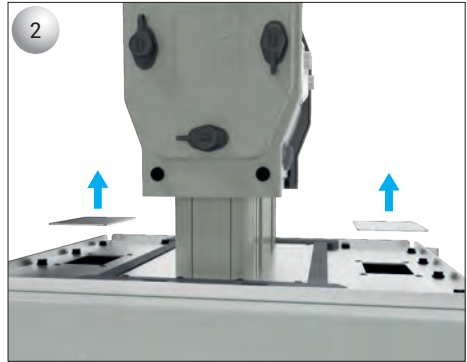
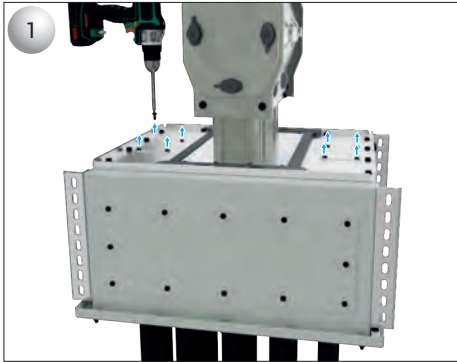

E-LINE CCR MANUAL

►► CCR B10 Feeder Box Installation Manual / Edgewise

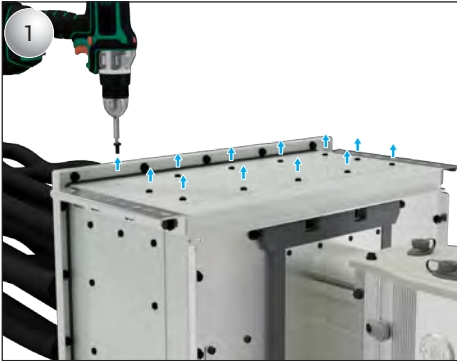

E-LINE CCR MANUAL

►► Electrical site-tests

► EJunction Resistance Test

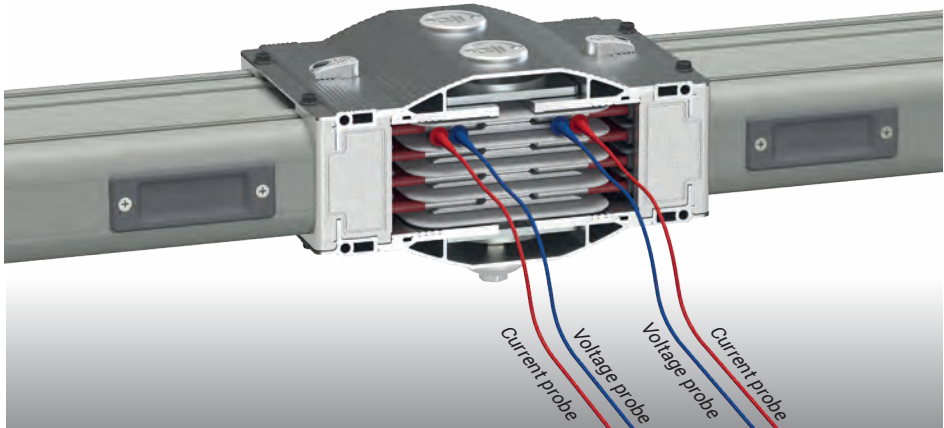

$$R_{\max} \leq 15 \mu\Omega$$

► Line Insulation Resistance Test

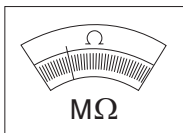
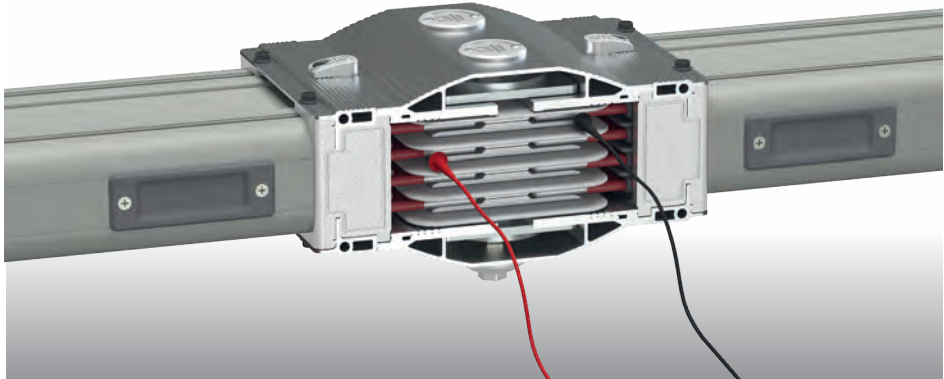

$\geq 1M\Omega$ OK
 $< 1M\Omega$ NOT OK

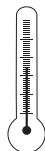

$< 5^{\circ}C$ ► STOP
 $> 35^{\circ}C$ ► STOP

T(°C)

E-LINE CCR MANUAL

►► Annex A Site Joint Test Instruction



PURPOSE

Joint resistance must be measured to ensure contact quality and to prevent the busbar from overheating during operation. The purpose is to measure the joint resistances of CCR type of busbars' of EAE branded.

SCOPE

This test instruction covers CCR type of EAE branded busbars whose joint resistance is to be measured. Since the measurement of joint resistance is not defined in the relevant busbar standards, this test instruction has been prepared based on OHM law.

APPLICATION OF THE TEST

The OHM law is based on a four-wire measurement in this test: a constant current is injected and the resulting voltage drop is used to calculate the resistance.

Joint resistance measurement points for a representative joint connection are given in Figure 1.

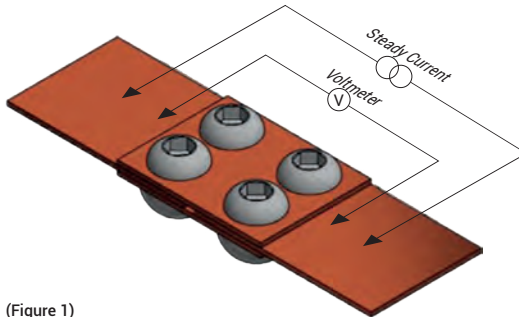

(Figure 1)

The diagram given in Figure 1 is a reference for joint resistance measurement for all kinds of joint connections.

Joint connections may differ in different product types, but basically, measurement in all joint structures is based on the same logic.

E-LINE CCR MANUAL

►► Annex A Site Joint Test Instruction



Joint structures of EAE busbars of CCR model is shown in the drawing below.

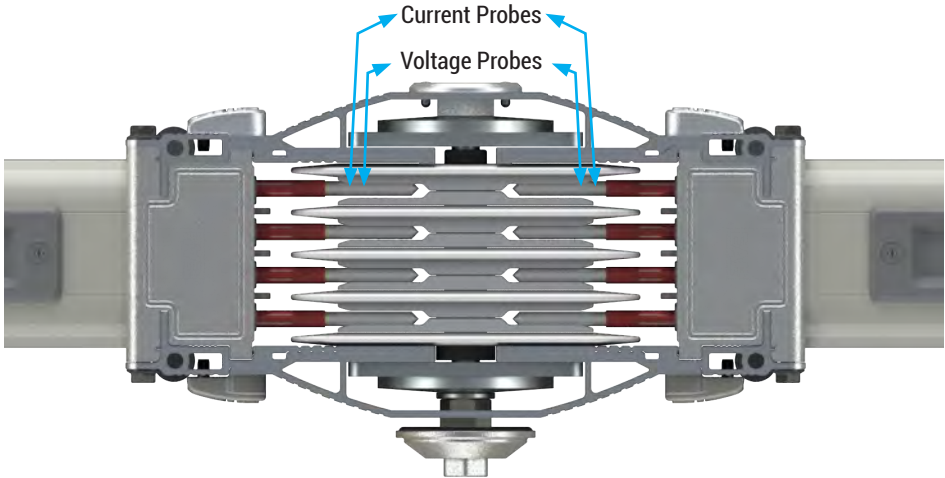

Measurements should be made with a four-wire DC low resistance.

The probes of the device should be connected to the joint structure as shown in Figure 1. A four-wire, calibrated OHM meter that applies at least DC 10 Amperes should be preferred.

The most suitable measuring probes should be used according to the joint structure.

As shown in Figure 1, joint resistance measurements are made after the measurement probes are connected to the joint connection.

Joint transition resistance measurements are repeated at least twice to ensure the measurement result.

The difference in resistance value measured for L1, L2, L3 and N conductors in the same joint can not be more than 10 $\mu\Omega$.

Joint transition resistance measured for PE conductor can not be more than 100m Ω .

Maximum joint transition resistance is 25 $\mu\Omega$. All values below this value are considered acceptable.

DANGER

HAZARD OF ELECTRIC SHOCK, EXPLOSION, OR ARC FLASH

- Apply appropriate personal protective equipment (PPE) and follow safe electrical work practices. See NFPA 70E.
- This equipment must be installed and serviced only by qualified electrical personnel.
- Before performing visual inspections, tests, or maintenance on this equipment, disconnect all sources of electric power. Assume all circuits are live until they are completely de-energized, tested, and tagged. Pay particular attention to the design of the power system. Consider all sources of power, including the possibility of backfeeding.
- Always use a properly rated voltage sensing device to confirm power is off.
- Close covers at all unused openings.
- Handle this equipment carefully and install, operate, and maintain it correctly in order for it to function properly. Neglecting fundamental installation and maintenance requirements may lead to personal injury, as well as damage to equipment or other property.
- Carefully inspect your work area and remove any tools and objects left inside the equipment.
- Replace all devices, doors, and covers before turning on power to this equipment.
- All instructions in this bulletin assume that the customer has taken these measures before performing maintenance or testing.

Failure to follow these instructions will result in death or serious injury.

Important!

Hazardous voltages in electrical equipment can cause severe personal injury or death. Unless otherwise specified, installation, inspection, and preventive maintenance should only be performed on busway systems where the power has been turned off, disconnected, and electrically isolated so that accidental contact with energized parts is not possible. Operation of busway trunking that has been exposed to water or moisture can cause property damage, serious injury, or death. It is essential to ensure that insulation resistance is adequate and that all sources of moisture have been eliminated before re-energizing the system.

- 1- Carefully inspect all visible electrical joints and terminals. During this inspection, confirm that all bolts and nuts are correctly and securely tightened to maintain reliable Melectrical contact.
- 2- Check the torque of all joint bolts. If the torque on any joint bolt is found to be less than 61 lb-ft (83 Nm), contact an EAE representative. Insulators may have been damaged due to overheating, and simply re-torquing the bolts in such cases may lead to further damage and could cause a busway outage.
- 3- If any joints or terminations appear badly discolored, corroded, pitted, or show any signs of exposure to high temperature, the affected components must be replaced with new, factory-built parts to ensure the safety and integrity of the system.
- 4- Check the insulation resistance before re-energizing the busway. Maintain a permanent record of insulation resistance readings. If these readings decrease significantly over time, it is an indication of insulation deterioration. Perform this test following the procedure

described in the section titled "Before Energizing" on page 9.

5- Re-energize the equipment according to the instructions provided in the section titled "Energizing the Equipment" on page 9. Ensure all inspection and testing steps have been properly completed prior to restoring power.

6- After completing inspections and any necessary repairs, it is recommended to perform an infrared temperature test on all electrical connections. This should be done after the busway system has been re-energized and allowed to operate until it reaches a stable temperature. The infrared inspection helps identify potential hot spots or loose connections.

7- An external inspection of the system should be conducted at least once each year. During this inspection, verify that there is no accumulation of dust, dirt, or other contaminants that may affect system performance or safety.

8- Any dripping, leakage, condensation, or other sources of moisture near the busway modules must be eliminated from the installation area to prevent insulation failure, corrosion, or electrical hazards.

9- To prevent loosening that may occur in connections, hangers, and similar equipment due to vibration, a visual inspection of the line should be performed at least once a year.

Important: Hydrocarbon spray propellants and hydrocarbonbased cleaning or lubrication compounds can degrade certain plastic components in the busway system. Contact EAE before using such products for cleaning, drying, or lubrication during installation or maintenance.

E-LINE CCR MANUAL

►►EAE Electrical Site Test Report



► Junction Resistance Test Report

Customer:		Date:/...../.....
Project:		Order No:
Address:		U _n : V	I _n : A
Busbar Code:		Material: AL <input type="checkbox"/> CU <input type="checkbox"/>	Conductor Section: x mm ²
Line:		Required Torque:	M12 83Nm
Note: The tests have to perform only with calibrated devices.			Calibration Date:/...../.....

Results

Junction :		Junction :		Junction :		Junction :		Junction :	
Phase	R (μΩ)	Phase	R (μΩ)	Phase	R (μΩ)	Phase	R (μΩ)	Phase	R (μΩ)
N - N		N - N		N - N		N - N		N - N	
L1 - L1		L1 - L1		L1 - L1		L1 - L1		L1 - L1	
L2 - L2		L2 - L2		L2 - L2		L2 - L2		L2 - L2	
L3 - L3		L3 - L3		L3 - L3		L3 - L3		L3 - L3	
PE - PE		PE - PE		PE - PE		PE - PE		PE - PE	
Torque: Nm	Torque: Nm	Torque: Nm	Torque: Nm	Torque: Nm
Max Value: μΩ	Max Value: μΩ	Max Value: μΩ	Max Value: μΩ	Max Value: μΩ

Junction :		Junction :		Junction :		Junction :		Junction :	
Phase	R (μΩ)	Phase	R (μΩ)	Phase	R (μΩ)	Phase	R (μΩ)	Phase	R (μΩ)
N - N		N - N		N - N		N - N		N - N	
L1 - L1		L1 - L1		L1 - L1		L1 - L1		L1 - L1	
L2 - L2		L2 - L2		L2 - L2		L2 - L2		L2 - L2	
L3 - L3		L3 - L3		L3 - L3		L3 - L3		L3 - L3	
PE - PE		PE - PE		PE - PE		PE - PE		PE - PE	
Torque: Nm	Torque: Nm	Torque: Nm	Torque: Nm	Torque: Nm
Max Value: μΩ	Max Value: μΩ	Max Value: μΩ	Max Value: μΩ	Max Value: μΩ

The maximum values per type and explanation to execute this test can be found in Annex A Electrical Site Tests of CR Manual

Remarks

Witnesses

Name	Company	Date	Signature

E-LINE CCR MANUAL

►►EAE Electrical Site Test Report



► Line Insulation Resistance Test Report

Customer:		Date:/...../.....
Project:		Order No:
Address:		U_s : V	I_s : A
Busbar Code:		Material: AL <input type="checkbox"/> CU <input type="checkbox"/>	Conductor Section: x mm ²
Line:		Result by: V (DC)
Note: The tests have to perform only with calibrated devices.		Calibration Date:/...../.....

Recommended Test Voltage 1000 V DC

Results

	Before Casting	After Casting	
N - L1	=	/	MΩ
N - L2	=	/	MΩ
N - L3	=	/	MΩ
N - PE	=	/	MΩ
L1 - L2	=	/	MΩ
L1 - L3	=	/	MΩ
L1 - PE	=	/	MΩ
L2 - L3	=	/	MΩ
L2 - PE	=	/	MΩ
L3 - PE	=	/	MΩ

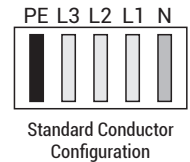

Remarks

Witnesses

Name	Company	Date	Signature

CE DECLARATION OF CONFORMITY

Product Group	E-Line CCR Busbar Energy Distribution System
Manufacturer	EAE Elektrik Asansor End. Insaat San. ve Tic. A.S. Akcaburgaz Mahallesi, 3114. Sokak, No:10, 34522 Esenyurt - Istanbul

The objects of the declaration described below is in conformity with the relevant Union harmonisation legislation. This declaration of conformity is issued under the sole responsibility of the manufacturer.

Standard:

TS EN 61439-6

Low-voltage switchgear and controlgear assemblies - Part 6: Busbar trunking systems (busways)

CE - Directive:

2014/35/EU "The Low Voltage Directive"

2014/30/EU "Electromagnetic Compatibility (EMC) Directive"

Technical Document Preparation Official ;

EAE Elektrik Asansor End. Insaat San. ve Tic. A.S.
Akcaburgaz Mahallesi, 3114. Sokak, No:10 34522 Esenyurt-Istanbul

Mustafa AKÇELİK

Date

03.03.2025

Document Authorized Signatory















Elif Gamze KAYA OK
Deputy General Manager



E-LINE CCR MANUAL

►► Certificates



			
<p>For the product:</p>	<p>Low-voltage busbar trunking system</p>		
			
<p>Requirements:</p>	<p>IEC 61439-6: 2012; Clauses: 10.2.3, 10.2.6, 10.2.7, 10.2.101, 10.3, 10.4, 10.5, 10.9, 10.10, 10.11 and Annex BB, CC, and DD</p>		
			
<p>is gr s bee ttestr oduct 13</p>	<p>ists amit B S) asse ed b ber:</p>	<p>it lengt jits of mitted er's pr nsibili</p>	<p>is certificate and adjoining reports is allowed</p>
	<p>DEKRA Certification B.V.</p>  <p>F.S. Strikwerda Certification Manager</p>		
<p>DEKRA Certification B.V. Utrechtseweg 310, 6812 AR Arnhem, P.O. Box 5185, 6802 ED Arnhem, The Netherlands T +31 88 96 83000 F +31 88 96 83100 www.dekra-certification.com Company registration 09085396</p>			

600A...6300A COMPACT BUSBAR PRODUCT OVERVIEW (E-LINE CCR)

1- Standards & Certification:

-Busbar trunking system shall be designed, type tested and, manufactured in accordance with the International standard IEC 61439-6. Type test shall be documented by independent and internationally accredited testing and certification bodies. Short circuit type tests shall be conducted by independent and accredited testing and certification bodies. Short circuit type tests and the following 3 main type tests shall be conducted for each current rating of the busbar system and conformity to the standards certificates obtained.

2- General Structure Of The System

-The busbar system should be low impedance in accordance with the following characteristics. The tin coated conductors are arranged as a sandwich construction inside the resin body without any air gaps.

2.1- Electrical Characteristics

-Busbar systems nominal insulation voltage shall be 1000V
-As per ampere rates, minimum short circuit values shall be as given below;

For Aluminium Conductors;

600A	: 1 sec/rms	25kA, peak	52,5kA
800-1250A	: 1 sec/rms	35kA, peak	73,5kA
1600A	: 1 sec/rms	60kA, peak	132kA
2000A	: 1 sec/rms	80kA, peak	176kA
2500A and above	: 1 sec/rms	100kA, peak	220kA

For Copper Conductors;

650-850A	: 1 sec/rms	35kA, peak	73,5kA
1000A	: 1 sec/rms	50kA, peak	105kA
1250-1600-2000A	: 1 sec/rms	80kA, peak	176kA
2500-3200A	: 1 sec/rms	100kA, peak	220kA
3400A and above	: 1 sec/rms	120kA, peak	264kA

2.2- Housing

-The housing of the busbar system shall be manufactured with specially developed cast material.

-The structure of the busbar lengths shall have conductors tin plated along their complete length within the housing.

-Multi-path busbars should be combined in a single body so that they are not separated from each other.

-Up and down, right-left turn elements, "T" and offset elements, panel, transformer and cable connectors, termination, horizontal and vertical expansion elements should be standard in the Busbar trunking system. Special modules and different lengths busbar ducts that may be required during the application of the project must be manufactured in a short time in accordance with standard specifications and technology.

-If busbar runs pass through the building expansion joint a horizontal expansion element shall be used in the run. In addition horizontal expansion elements should be used every 40 m along a horizontal run.

2.3- Conductors and Phase Configuration

- Compact busbar system shall have aluminium conductors between 600A – 5400A.
- Compact busbar system shall have copper conductors between 650A – 6300A.
- Busbar system shall have the following number of conductors and wire configuration.

- a) 3 Conductors
- b) 4 Conductors
- c) 4 ½ Conductors
- d) 5 Conductors

- Neutral conductor shall have the same cross section as the phase conductor cross section.
- Aluminium conductors shall be of EC grade aluminium. Minimum conductivity shall be 34m/mm².Ω. All surfaces of aluminium conductors shall be tin plated.
- Copper conductors shall be minimum 99,95% electrolytic copper. Minimum conductivity shall be 56m/mm².Ω. all surfaces of electrolytic copper conductors shall be tin plated.

2.4- Insulation

- Busbars shall be insulated using a mixture of specially selected silica and calcite mixed with an electrical grade epoxy resin to make a superior composite material. This insulation material must have a high impact resistance against external impacts.

2.5- Modular Joint Construction

- The busbar lengths must be joined together with the joint's point drawer type modular block joint system by placing the conductors in the conductive socket in the block insert. Joint block insulators should be high strength CTP insulators. The joint block's centre bolt should be tightened with a torque wrench set to 83 Nm (60 lb ft) after installation.

2.6- Protection

- Protection degree of the housing and joints shall be IP68.

3- Installation and Commissioning

- The installation of the busbar system should be done in accordance with the type and current values shown in these plans in accordance with the electrical project, electrical single line schemes, layout plans and detailed busbar application projects, the manufacturer's installation instructions must be observed carefully during the assembly process. The central joint's bolts must be tightened with the appropriate torque wrench and the nut side of the bolt must be secured with the nut locking cap.
- After installation of the busbar system the installation should be checked for compliance with the manufacturer's instructions and the requirements of the project, an insulation test should be done. Insulation resistance between all conductors and body has to be bigger than 1 megaohm.

SUSTAINABLE FUTURE

Sustainability Management at EAE Elektrik



As part of our goal to support sustainable development and green transformation, measuring, evaluating, and managing all economic, environmental, and social impacts resulting from our sustainability practices is a key governance priority for EAE Elektrik. We act with great care in analyzing, monitoring, and managing the economic, environmental, and social impacts and risks that arise throughout our value chain in both our national and global operations.

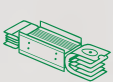

Busbar Systems

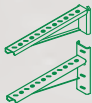

Support Systems



Cable Tray Systems

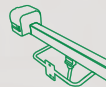

Trolley Busbar Systems



Fit-Out Solutions

"We are working together with all our stakeholders to develop the electrical technologies that will build the future."

You can visit our sustainability website at sustainability.eaeelectric.com



#FutureTogether

EAE Elektrik
Head Office

Akcaburgaz Mahallesi,
3114. Sokak, No: 10 34522
Esenyurt - Istanbul - Turkiye
Tel: +90 (212) 866 20 00
Fax: +90 (212) 886 24 20

EAE DL 3 Factory
Busbar

Organize Sanayi Bolgesi Mahallesi,
6. Cadde, No: 6A, 41455
Dilovasi - Kocaeli- Turkiye
Tel: +90 (262) 999 05 55
Fax: +90 (262) 502 05 69



Please visit our website for the updated version of our catalogues.
www.eaeelectric.com



Manual 58 - En. / Rev.12 / 0 Pcs. / 14.05.2026

D.S.
EAE has full right to make any revisions or changes on this catalogue without any prior notice.