



# E-LINEKX

MANUAL



**E-LINEKX**





## CONTENTS

---

Introduction .....	2
General.....	3-4
Handling & Storage .....	5-6
Points To Be Taken Into Consideration Before Installation.....	7-8
Joint Structure.....	9
General View Of The Joint .....	10
Determination Of Special Lengths & Offset Sizing .....	11
Mounting Instructions For Joints (Bolt-on / Plug-in).....	12-14
Points To Be Taken Into Consideration After Installation.....	15-17
Measuring a Special Length.....	18-19
Riser & Vertical Applications .....	20
Plug-in Busbar Tap Off Boxes (KXP).....	21-22
Bolt-on Busbar Tap Off Boxes (KXB) .....	23-26
Cable Feed Box Installation (B10,B11)) .....	27
Energizing / Before Energizing .....	28
Energizing The Equipment.....	29
Maintenance.....	30



Please read the instructions contained in this publication thoroughly and follow the directions provided carefully.

### Dear Customer,

EAE Elektrik A.S. Products are designed and manufactured to provide the maximum benefit in efficiency and service. Our products are manufactured in accordance with Management Systems standards and EAE quality standards at our modern production facilities in Istanbul.

The components that you have purchased are manufactured by an environmental conscious team, with the relevant knowledge of the Environmental Management Standards. Our employees work strictly in accordance to the principles of the information Security Management systems, and conform to the rules of the occupational health and safety act.

Installation, handling and operation of products should only be conducted by highly skilled, trained and authorized personal utilizing all affiliated equipment such as rubber gloves, helmet, flame resistant clothing and glasses or face shields in accordance with the prevailing safety procedures.

1- Installation and planning of the Busbar system, and collaboration with other distribution systems (mechanical, heat, steam, air installation etc.) are crucial for the success of the project.

2- Operational Success of the Busbar systems are ensured by adhering to the right cartage, design and proper installation. Incorrect installation may cause malfunctioning, personal injury and damage to the operating systems.

3- The installation, operation and maintenance of the Busbar systems should only be performed by qualified personnel who are aware of the dangers associated with installation, construction, operation and intended usage, according to the manual.

\* Know the requirement of applicable electrical laws, other laws and standards.

\* Be trained and authorized to test, energize clean, ground, label and lock the system and equipment suitable for occupational safety applications.

\* Be trained in the use and maintenance of personal protective equipment such as rubber gloves, helmets, protective goggles or face shields and flame resistant clothing in accordance with the relevant safety practices and potential hazardous levels.

\* Must be trained in first aid.

### **WARNING:**

High voltage levels in the electrical components may result in serious injury or death.

Installation, monitoring and maintenance must be performed on a de-energized Busbar. Therefore, unintentional contact with energized equipment is prevented. All warnings and instructions must strictly be adhered to.

### **WARNING :**

High voltage levels in the electrical components may result in serious injury or death. Operation of the Busbar, that is damaged by moisture or water can cause serious personal injury or death and damage to property. To ensure proper installation and to remove the moisture source, refer to the notes on page 16 item number 13.

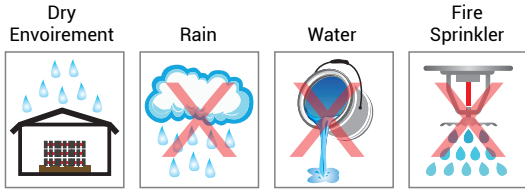

**BUSBARS SHOULD NOT BE IN CONTACT WITH ANY LIQUID**

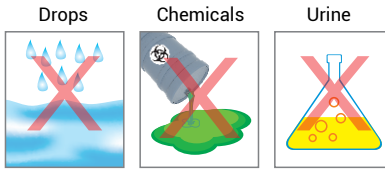

**CLOSE INDIRECT OR DIRECT WATERWAYS.**

Please use canopy for outdoor applications.



Please use porch for outdoor.

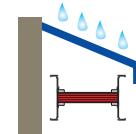

Please use porch for outdoor.



Please use canopy for building expansion points.

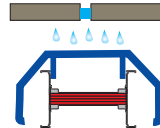

To prevent liquids from entering shaft openings, a curb with a minimum height of 100 mm must be installed around all floor openings containing vertical busbar lines.

(See NEC Article 368.6)

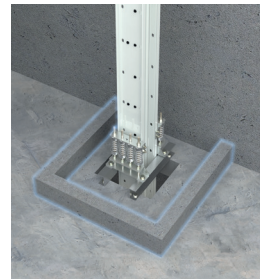

**BUSBARS THAT ARE NOT COMPLETELY ASSEMBLED HAVE NO PROTECTION AGAINST WATER**

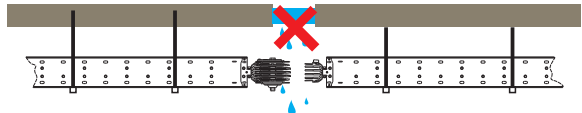

Contact with liquids and corrosion will negatively affect the design performance of the products in terms of both mechanical and electrical properties (Ground continuity, short-term fault endurance, and current-carrying/temperature rise characteristics).

1- General guidelines are provided to protect the Busbar lengths and modules, thereby reducing the risk of personal injury and equipment damage handling on site.

2- As soon as the container or trucks arrives on site, a suitable forklift is required for essay and convenient unloading. The pallets must not pulled with a rope, etc. material.

3- All pallets should be checked by unpacking them to inspect for possible transit damage and to determine that the shipment is correct as per Packing List.

\* If any of the items are missing from the consignment or any items are damaged during transportation. The insurance Company must be notified immediately and all required documents completed.

4- All Busbar lengths and modules should be handled with care to avoid damage to internal components and the distortion of the housing or its finish.



5- When the Busbars and modules are required remove them from the pallets by inserting metal rods through the 2 sets of holes situated at the ends of the housings, therefore ensuring that the load is balanced and safely secured. By using adequate slings and the slinging method the components can be moved safely from one place to another.

6- The moving of products from one floor to another floor must be performed by means of a suitable electric, mechanical crane or elevator.

7- If storage is required before installation and repacking is necessary it should be performed as close as possible to the point of installation however it should not be disassembled, until it reaches its final installation position depending on various conditions. (Refer to chapter 5)

8- The Storage area should be clean and dry with a constant temperature to prevent condensation, having adequate air circulation and has to be protected from dust, fumes and moisture. The storage area should be vehicle free to prevent damage to the products.

9- When the Busbar straight lengths and modules are to be stored for a certain period of time before installation. The packaging should be repacked (if necessary) on wooden or plastic pallets for protection during that period. It should be stored in a protected area and covered with a waterproof canvas which offers protection against dust and any form of liquid contamination.

10- The Busbars that are designed for outdoor use is not weatherproof until the installation is completed. The above recommended storage parameters must be adhered to for any remaining busbars.

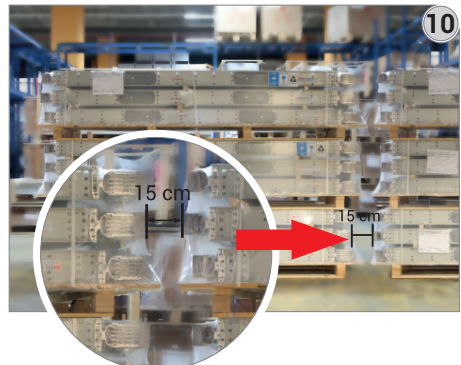

#### IMPORTANT!

1- Please read the instruction manual before commencing the Busbar installation. Incorrect or rudimentary installation may caused damage to the equipment or systems.

2- Installation of the Busbar systems should only commence after understanding and interpreting the Busbar application drawings. Locate the positions of individual components such as expansion units, feeder units, feeder unit ends and transformer panel connections, etc. These should always be executed according to the project drawings

3-All busbar products are 100% isolation resistance tested before shipment to our valued customers world wide. Unloading and storage must conform to our policies, pertaining to environmental conditions and construction sites. All Busbar products must be isolation resistance tested before installation commences, these include individual Busbar products, single conductors (between phases: phases and neutral and neutral and earth) Isolation Resistance Test (min. 1000V AC) is recommended. The measured value must not be less than 1(one) Megaohm. All products above 1(one) Megaohm may be installed.

Results may differ from country to country due to environmental conditions. Commencement of Installation without a isolation resistance test may lead to product failure, consequently the manufacturer (EAE Elektrik A.Ş) will not accept liability.

4- Seismic support systems should be used in high risk earthquake areas. Please contact our knowledgeable sales staff for details of seismic support products and project planning. The recommended distance between supports are 1.5m and the maximum is 2m. Ensure that support positions do not obstruct joint covers and tap off points.

5- DDT modules that are used on a concrete floor should be positioned at intervals of 20cm.

6- If the Busbar lines are used in the transition of the building dilatations, appropriate dilatation modules should be chosen. Please contact our knowledgeable staff for support.

7- Busbar systems should be installed with care when using a forklift, crane or pallet trolleys to avoid any damage. When transporting the products ensure that the weight is evenly distributed. Generally vertical installation is provided in vertical lines.

8- Please read the additional installation instructions.

9- When installing horizontal and vertical systems, ensure that it is aligned correctly to prevent distortion and collapsing. Protect the Busbar against water and moisture from unfinished roofs and walls during installation.

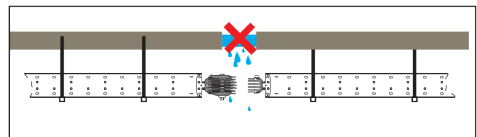
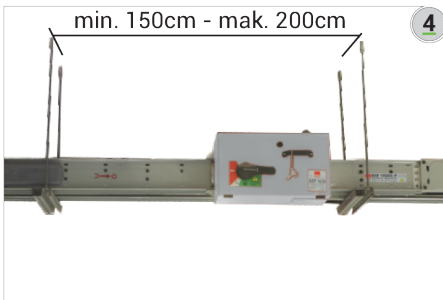

Please cover top of the shaft.

10- Tools required for the installation,

a- Micrometer, adjustable / calibrated torque wrench

b- 1/2 inch drive 10mm, 13mm and 19mm socket

c- 10mm Spanner/Socket

d- Screwdriver

e- Hoist with cloth sling

11- The Busbar to be installed must be secured and hoisted as shown in the picture below.

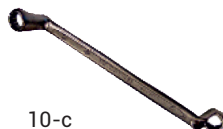
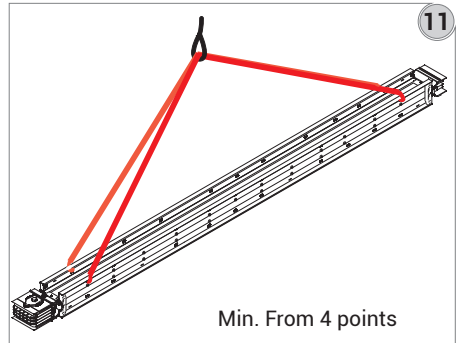

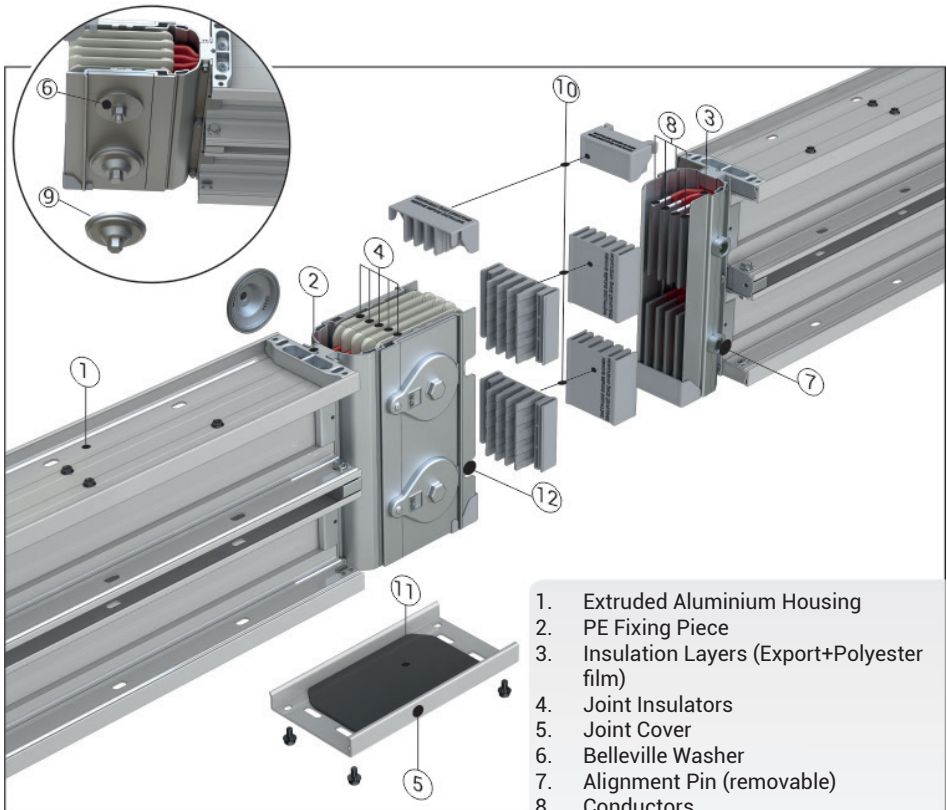

1. Extruded Aluminium Housing
2. PE Fixing Piece
3. Insulation Layers (Export+Polyester film)
4. Joint Insulators
5. Joint Cover
6. Belleville Washer
7. Alignment Pin (removable)
8. Conductors
9. IP55 Nut Locking Piece
10. Protection Covers
11. Ip55 Joint Cover Gasket
12. Alignment Pin Slot NB Protection covers 10 are discarded.

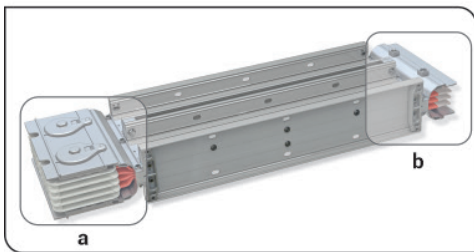

KX Busbars are manufactured in 3m standard lengths, however special lengths can be manufactured according to the project diagrams. All modules have a block joint end and no block joint on the opposite end.

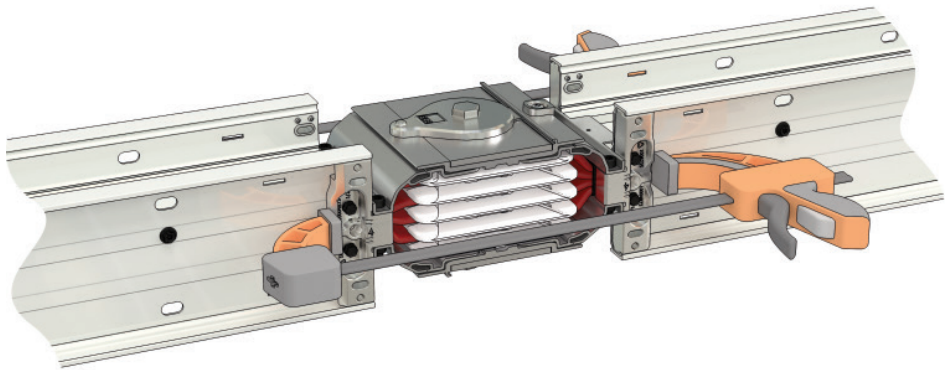
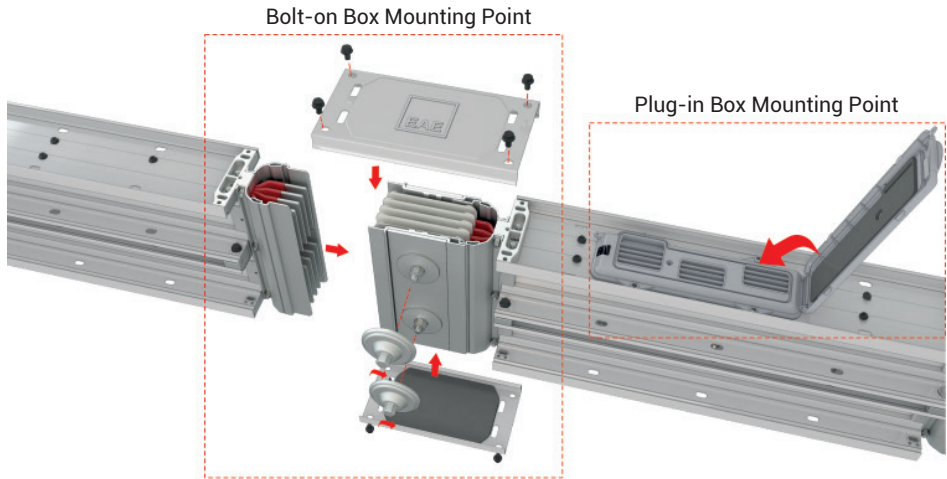

Use special clamps if installation is restricted.

1- Special lengths (particular or custom size) busbars are used in places where standard sizes do not fit. The minimum length for these special modules are 35cm. Please measure the lengths of these modules as shown below

2- Length A is measured between housing of 2 busbars in cm. "A" The special length is calculated by deducting 25cm from this measured length.

$X = A - 25$  (cm) X=Length of Special Busbar (The busbar module will be manufactured as per X value.)

3- In the case where custom made intermediate size Busbars are required, both ends of the intermediate size Busbars can be produced with or without block joints. In such cases, please contact our knowledgeable sales staff for technical information and support.

**Note:** Please supply a drawing for combined offsets when ordering. Indicate bolted and unbolted ends on the drawing.

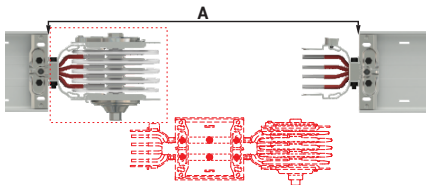

Aluminium		Copper		A	B	X
Rated Current	Busbar Code	Rated Current	Busbar Code	(mm)	(mm)	(mm)
400	04	550	05	252	214	427
500	05	650	06	257	217	432
630	06	800	08	267	222	442
800	08	1000	10	282	229	457
-	-	1250	12	297	236	472
1000	10	1350	14	307	241	482
-	-	1600	17	322	249	497
1250	12	-	-	337	256	512
1350	14	2000	23	352	264	527
1600	17	-	-	387	281	562
2000	20	2500	25	427	301	602
2500	27	-	-	477	326	652
-	-	2000	22	377	276	552
-	-	2500	27	407	291	582
2500	25	3300	32	487	331	662
-	-	3600	36	517	346	692
3150	32	4000	40	547	361	722
3200	33	-	-	587	381	762
4000	40	5000	50	667	421	842
5000	51	-	-	767	471	942
-	-	6300	63	907	541	1082
6300	63	-	-	1057	617	1232

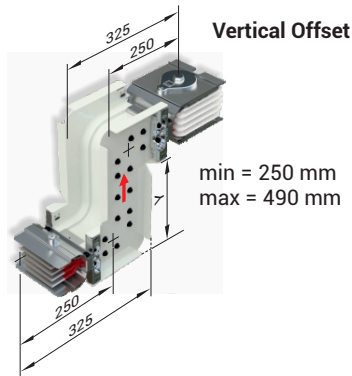

X=min:280mm, max: Use table.

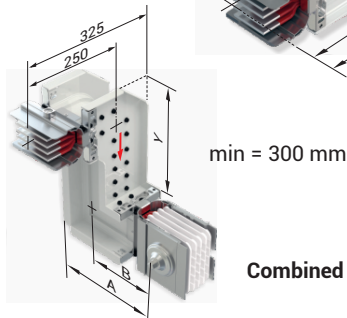
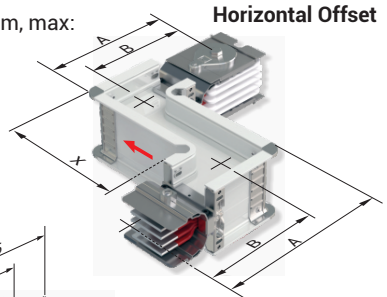

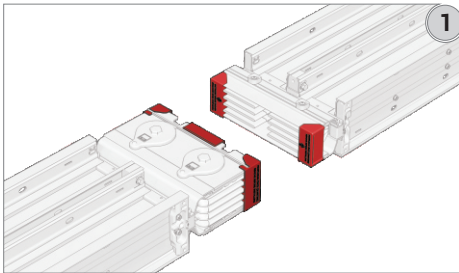

1- Align the two Busbars so that the sections with and without block joints are opposed.

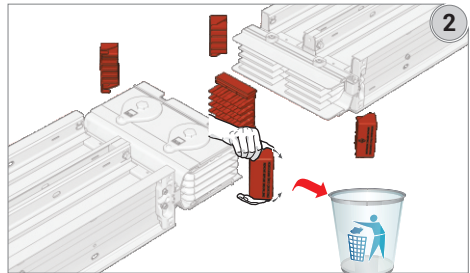

2- Remove the protective side covers on the no block joints.

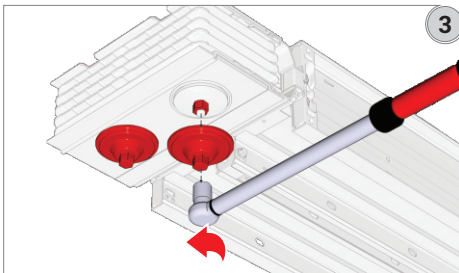

3- Remove the nut locking piece on the busbar joint and loosen the joint. Remove the protective covers after loosening the joint.

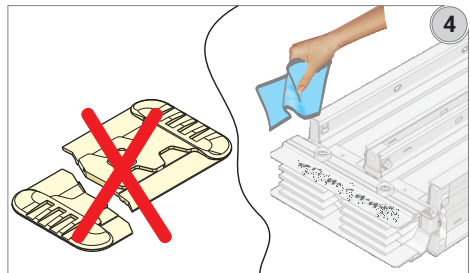

4- Ensure that the insulation plates of the joint, are not cracked, broken or damaged in anyway. Wipe the dust off conductor surfaces with a cloth, so that no serious damage can be caused.

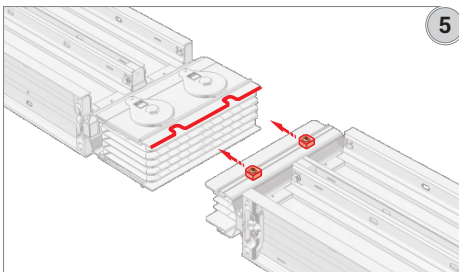

5- Align the block joint to the opposite busbar's end.

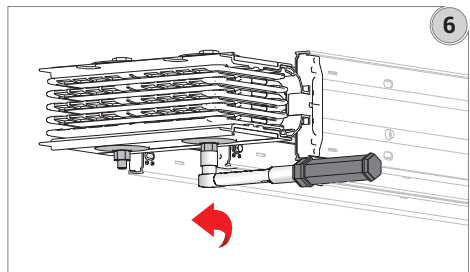

6- Loosen the nut at the connection point.

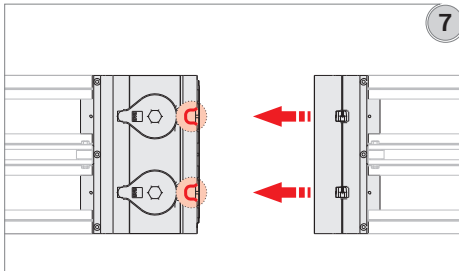

7- Adjust the channel in order to pivot the alignment component to the housing.

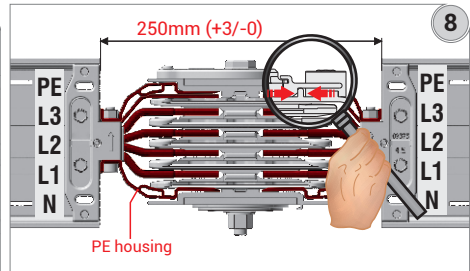

8- Coerce the two Busbars until they rest on each other.

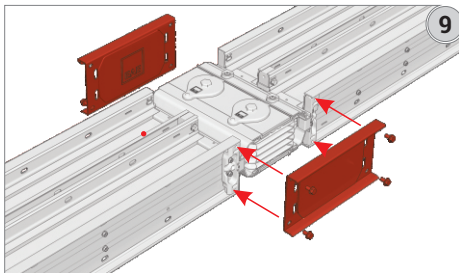

9- Assemble both the joint covers with the gaskets facing outward.

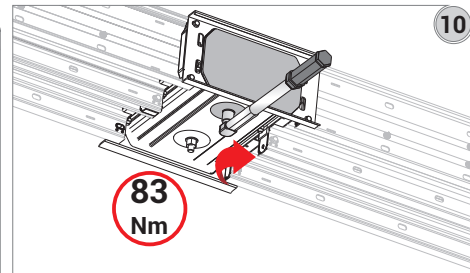

10- Adjust the torque wrench to 83 Nm (60 lbf) and tighten the joint nut.

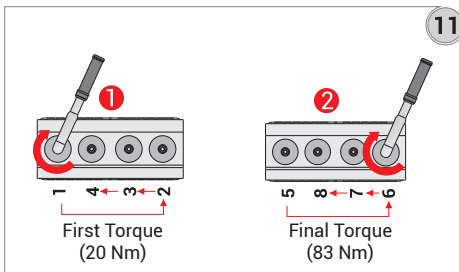

11- If there is more than one bolt per phase, the bolts should be tightened by hand to approximately 20-30 Nm as per the sequence shown above. Then finally torque to 83Nm using the same sequence.

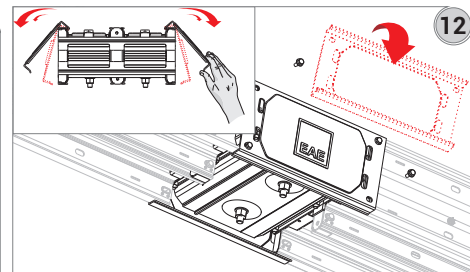

12- Remove the joint covers and reverse mount them with the gaskets facing inwards.

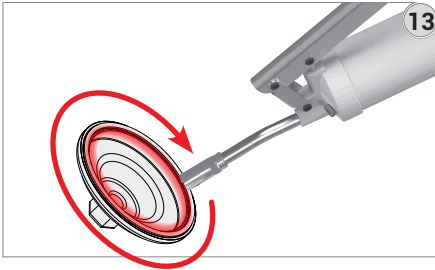

13- The nut protection cap gaskets should be lubricated properly. Please be ensure the entire surface of gasket is lubricated.

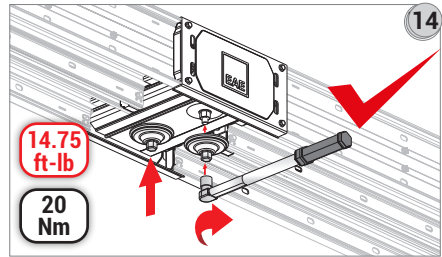

14- Finally tighten the dust cap 20 Nm (14.75 ft-lbs) to complete the installation.

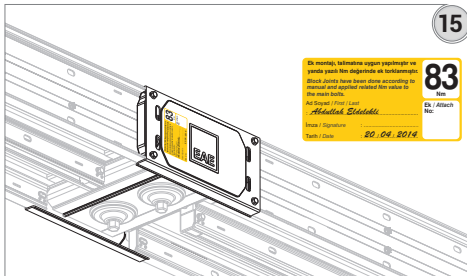

15- Please complete the label attached to the joint cover to verify that you are performing torque settings according to the specifications.

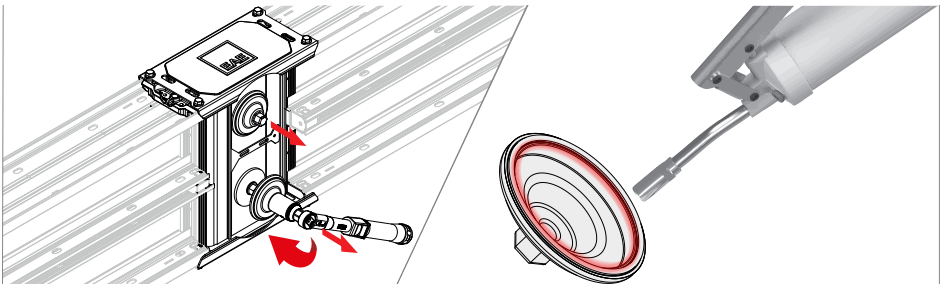

The nut locking piece are removable and reusable for maintenance and other situations. The nut protection cap gaskets should be lubricated properly.

Please be ensure the entire surface of gasket is lubricated. Tighten the nut protection caps with **14.75lb (20Nm)** before finalizing the assembly.

- Please note that environmental factors such as the amount of lubricant used during production, ambient temperature, humidity, and dust may affect the service life of the nut protection caps. Therefore, it is recommended to reapply lubrication 6 months after the production date. Additionally, due to the volatility of the lubricant, the lubrication process should be repeated whenever there is any doubt about its condition.
- It is recommended to use high-performance lubricants, such as greases Molykote Longterm W2, PROEASY VLF, Mobilgrease series, Shell Gadus series or equivalent products.

1- When the installation has been completed, please check the position of the neutral conductor along the busbar run. (Taking special care at locations where the run bends and offsets)

2- Carry out insulation test (minimum 1000V AC). Make sure that no protective device (switch, connector, etc.) is connected to the system and that the earth - neutral line is separate. All tap off boxes on the line must be set to «0». Keep in mind that the results can vary according to the Busbar length, width or number of bars. The results may also vary according to the moisture content.

Values should not be less than 1 MegaOhm / 30 meters. It is recommended that no energy is supplied to the line even if the insulation test is completed successfully.

2.3- After the Busbar system is energized, loads must be switched on in sequence (main and sub feed).

2.4- When the Busbar is used properly, it will have a moderate hum. Excessive noise may be an indication of hardware that has not been extruded or incorrectly mounted metal parts.

2.5- Spark formation at any point along the Busbar is abnormal. The Busbar must be de-energized until the spark situation is rectified.

3- Do not try to install five conductor units to four conductor units or vice-versa.

4- Do not apply any kind of oil or chemical at the joints or to the contacts of tap off boxes.

2.2 ELECTRICAL CHECKS (ELEKTRİKSEL KONTROLLER)				
MEGGER TEST (MEGGER TESTİ)				
Rated insulation Voltage (Busbar İzolasyon Gerilim Değeri): .....				
Megger Test Voltage (Çıyılanan Megger Test Gerilimi) : .....				
*(Test Voltage must be 1000V for busbars rated insulation voltage up to 1000V, test voltage must be 500V for rated insulation voltage up to 690V)				
*(Aynı izolasyon gerilimi 1000V'a kadar olan busbarlar için test voltajı: 1000V, 690V'a kadar olan busbarlar için test voltajı: 500V olmalıdır.)				
*(Measured resistances must be suitable for IEC 61439-1/11.9 standard.)				
*(Ölçülmüş dirençans değerleri IEC 61439-1/11.9 uygun olmalıdır.)				
L1-L2 : .....	Ohm > 1.0 MD	<input type="checkbox"/>	L3-N : .....	Ohm >
L1-L3 : .....	Ohm > 1.0 MD	<input type="checkbox"/>	L1-PE : .....	Ohm >
L2-L3 : .....	Ohm > 1.0 MD	<input type="checkbox"/>	L2-PE : .....	Ohm >
L1-N : .....	Ohm > 1.0 MD	<input type="checkbox"/>	L3-PE : .....	Ohm >
L2-N : .....	Ohm > 1.0 MD	<input type="checkbox"/>	N-PE : .....	Ohm >

[Explanation (Açıklama):

2.1- When the Busbar system is energized for the first time, qualified electrical personnel must be present. If short circuits and earth faults are detected due to any damage or faulty installation practices, serious damage can occur if the power is turned on.

2.2- When the power is supplied, there must be no electrical load in the Busbar.

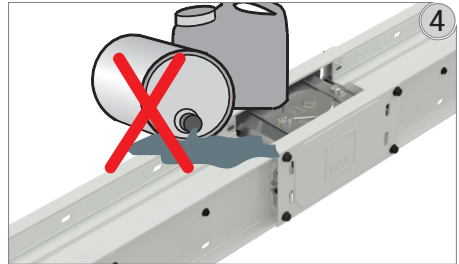

5- Do not use any other means than original tap off boxes to supply energy from the Busbar.

6- Current rating of the Busbar run should be equal to the rating of the breaker. Do not exceed Busbar nominal current during operation.

7- Make sure that any additional loads to the system do not exceed the nominal current capacity of the Busbar.

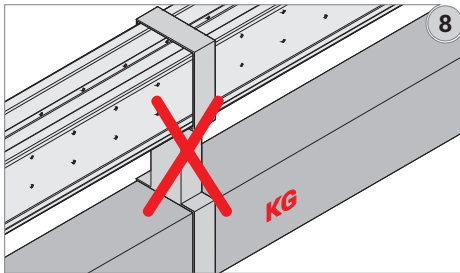
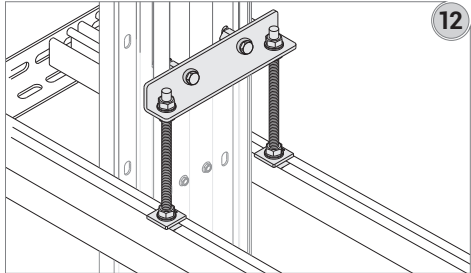

8- Do not use busbar system as a supporting structure for other systems.

9- Do not use the Busbar system as a walk way.

10- Do not light a fire or use welding equipment near the Busbar.

11- Take care when handling the system components. Do not drop the units.

12- Do not cut or drill the busbar units. Please take into consideration the picture below when installing the Busbar for vertical applications. Please do not drill the Busbar at any place where it is marked with red on the picture.

13- Take precautions against adverse environmental conditions such as rain and snow in addition, the Busbar dripping cement etc. inside the building. Protect from water, malfunctioning piping and all fluids that may come from water jets. Cover if necessary. Cap the ends of the Busbar joint points that have not been installed after completion of the work.

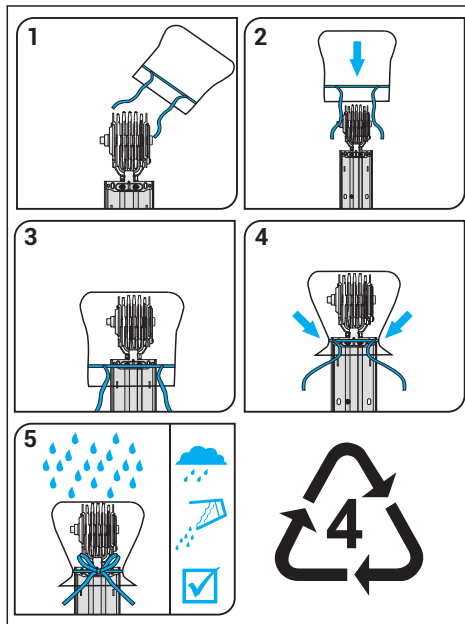

14- Ensure the selected degree of protection (IP rating) of the system is suitable for the working environment.

15- You can remove paint defects on product surfaces which could happen during transporting and installation operation by touching up with spray paint. (Information is also available about the paint color that you have ordered from the manufacturer). We recommend you clean the surfaces with a dry cloth in advance where the painting process will be.

#### WITHSTAND PERIODS AGAINST TO WATER AS PER STANDARD

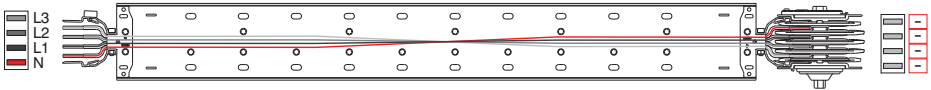

When installation of the Tap-Off Boxes are needed after the phase changer box, a customer representative needs to approve it in advance.

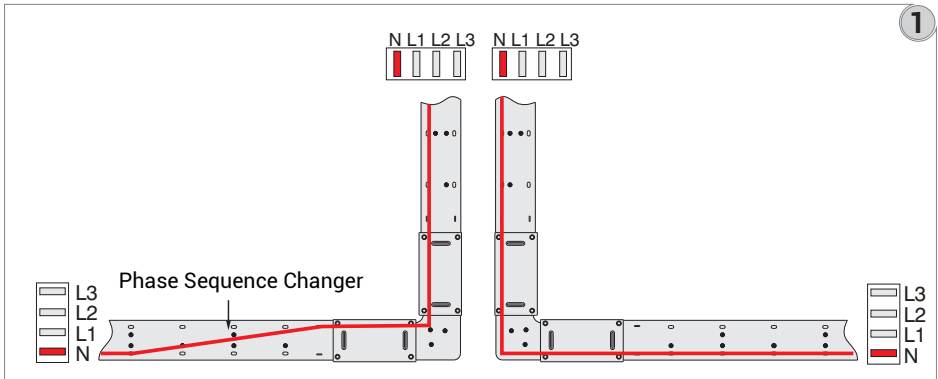

### Vertical Shaft Application

1- The neutral bar of KX Busbar shall be at the bottom for horizontal Busbar lines and on the left for vertical Busbar lines. (Figure 1)

2- In order to maintain the neutral bar at the bottom and in the vertical Busbar on the left, it is required to use the phase changing module. (Figure 1)

■ EAE is not responsible for the potential risks that may occur in cases where the products in our catalogue are used outside the standard phase sequences as demonstrated in the catalogue.

# KXMANUAL

## ►► Measuring a Special Length

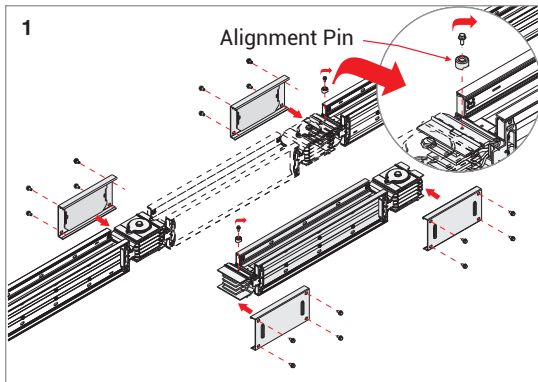

1- Remove Alignment Pin on the busbar, without block joint.

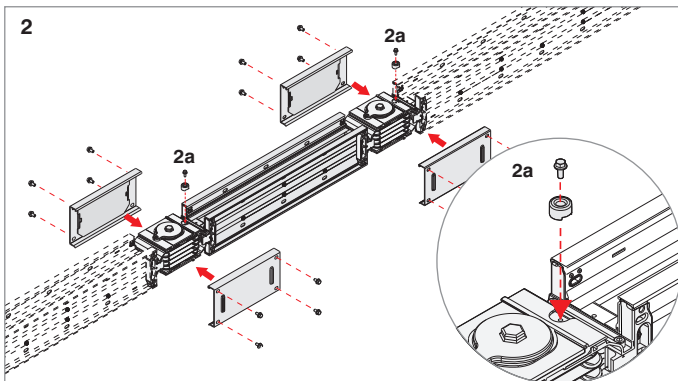

2- Insert the piece aligning conductors correctly. Fix back the Alignment pin.

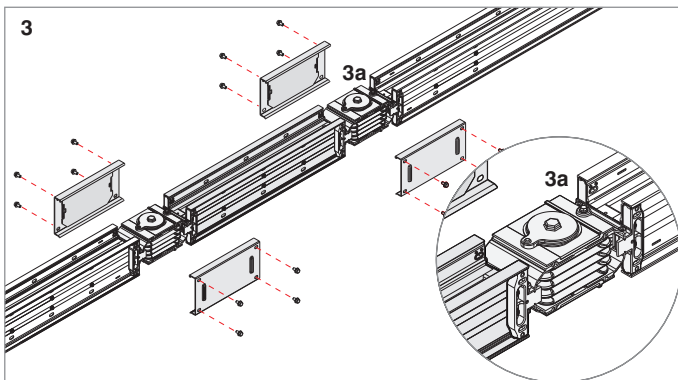

3- Make sure busbar piece is aligned according to alignment pin.

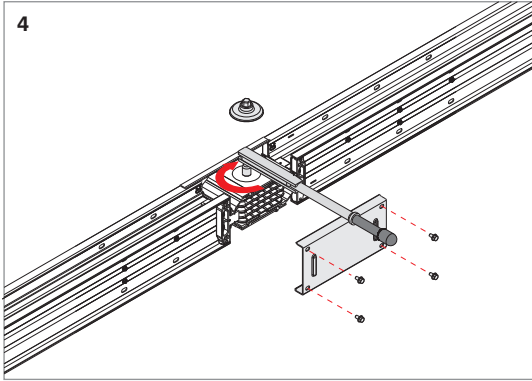

4- Fix one of the joint cover to stabilize joint. Apply **83Nm** to the main bolt.

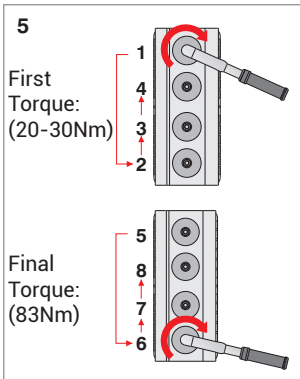

5- If there are more than one bolt for the same phase, bolts shall be tightened by hand approximately 20-30Nm as per above sequence, then 83Nm shall be applied at final torque with the same sequence.

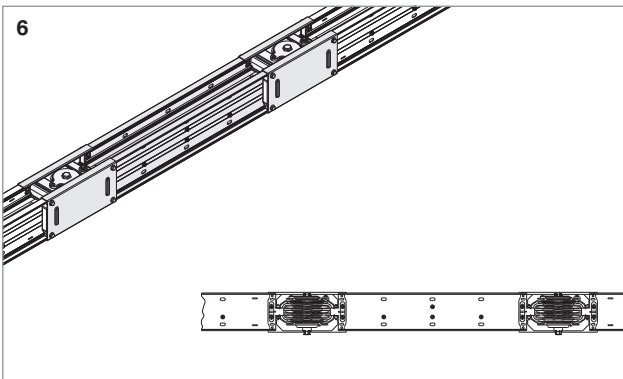



6- Fix the remaining joint cover. Joint installation is completed.

**Note:** If the final joint cover does not close correctly, it indicates the busbar is not completely aligned. Release the bolts and reapply the sequence from figure 4 to complete the joint.

As each building's structure is different. For vertical applications of the E-Line KX special projects need to be designed.

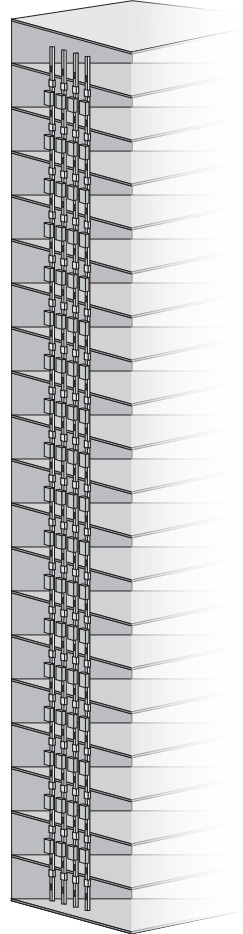
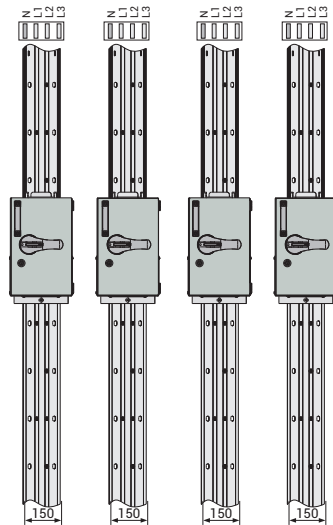
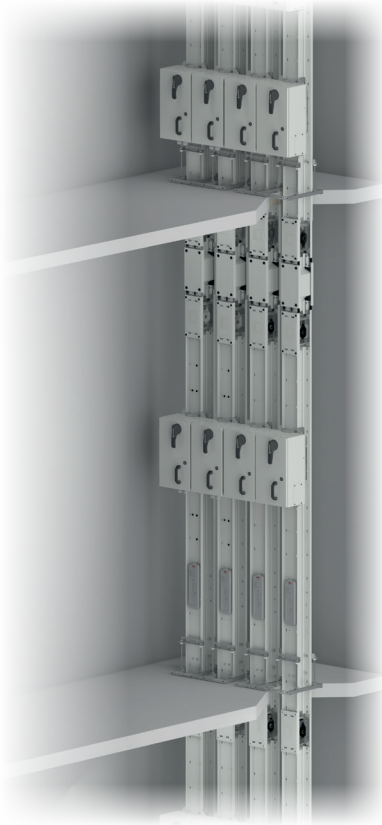
The details on this page briefly explains the necessary information for drafting a vertical application project.



 In multi-path Busbars in high-rise vertical shaft applications; Due to floor heights, floor thickness and product tolerances, the window or additional point alignments on the upper floors may not be the identical. In order for the Tap off boxes to be aligned and the joint point not to coincide with the floor transitions, the assembly should be continued by creating measurements on each floor.

In all buildings and structures, to prevent the propagation of fire between fire compartments, any horizontal and vertical penetrations of electrical installations from one fire compartment to another shall be properly sealed. All such openings must be closed using fire-stopping systems—such as fire-resistant mortars, pillows, panels, or equivalent materials—providing a fire resistance rating at least equal to that of the respective fire compartment.

**Warning:** The use of excessively fluid fire-stopping mortars may result in leakage through the busbar enclosure, potentially causing structural damage at joint interfaces and contact surfaces of tap-off units. Such conditions may lead to critical electrical failures, including short circuits and arcing faults. Therefore, it is essential that fire-stopping applications are performed using materials with appropriate viscosity and with installation methods designed to prevent leakage.

#### Vertical Application



#### Warning!

- \* Do not try to install plug-in tap off boxes to bolt-on the Busbar or vice versa.
- \* Do not try to install 4 wire tap off boxes to 5 wire the Busbar or vice versa.

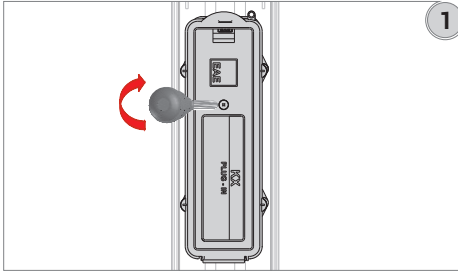

1-Remove the fixing screw of the "plug-in" tap off point cover using a star screw driver.

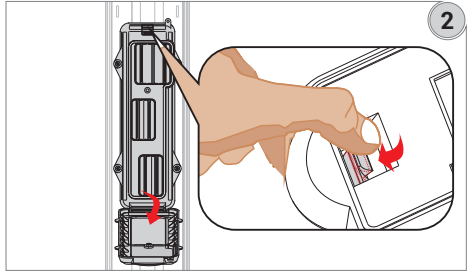

2-Open and push the cover back. The "plug-in" tap off point cover should be opened to a position which will not block the way for installation of the box. Do not remove the cover plate.

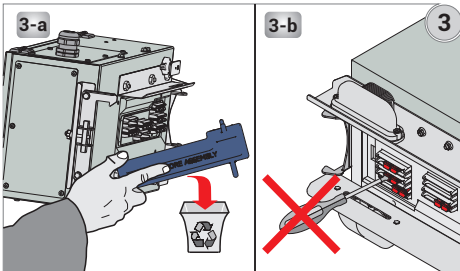

3-Throw the contact protection cover to the recycling waste bin. Make sure that you have brought the switch to zero position. As seen on figure 3-b, do not interfere with the jawed contacts. Do not deform them.

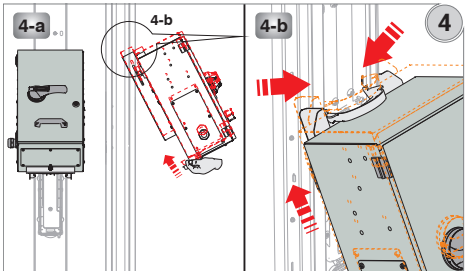

4-Place the KXP Plug-in tap off box into the holes on the Busbar at an angle. Push the tap off box upwards as shown in figure 4-b.

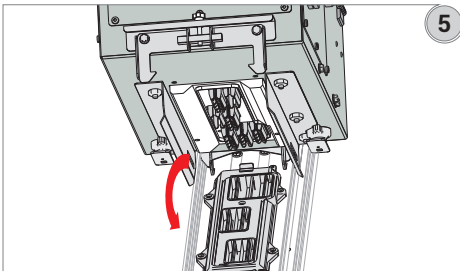

5-Check the alignment of the contacts. Push the box towards the Busbar.

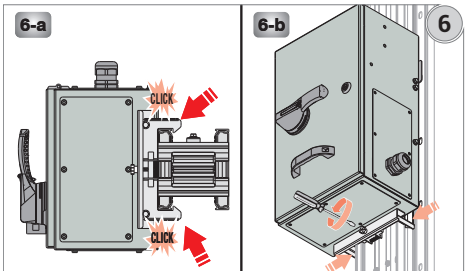

6-Push the box into the Busbar housing a "click" sound will be heard from the locking parts of the box ensure that it interlocks with the box and the housing thereafter tighten the screw.



During the installation of the tap-off box, if the box body comes to the busbar joint cover, there will be a risk that the contact will not fit properly on the busbar, so either the box installation should be done on a different suitable window or a busbar project revision should be requested. The box body should never be installed in a way that it coincides with the busbar joint point.

#### Horizontal Application

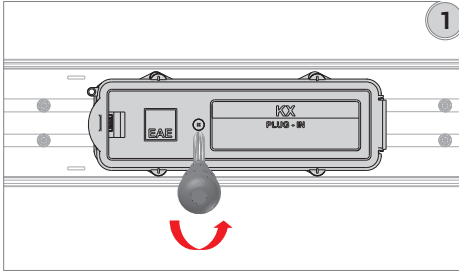

1-Remove the fixing screw of the "plug-in" tap off point cover using a star screwdriver.

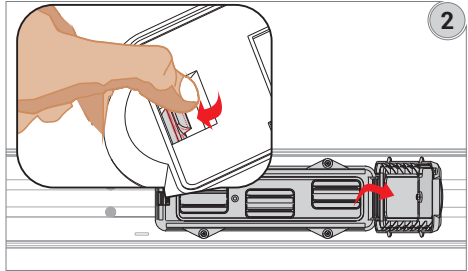

2-Open and push the cover back, the "plug-in" tap off point cover should be opened to a position which will not block the way for installation of the box. Do not remove the cover plate.

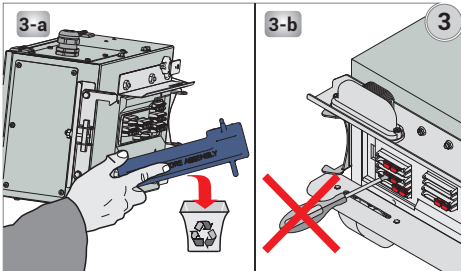

3-Throw the contact protection cover to the recycling waste bin. Make sure that you have brought the switch to zero position. As seen on figure 3-b, do not interfere with the jawed contacts. Do not deform them.

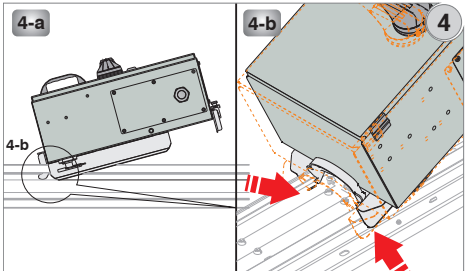

4-Place the KXP Plug-in tap off box on the holes of the Busbar at an angle. Push the tap off box upwards as shown in figure 4-b.

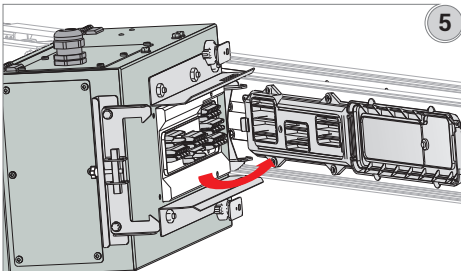

5-Check the alignment of the contacts. Push the box towards the Busbar.

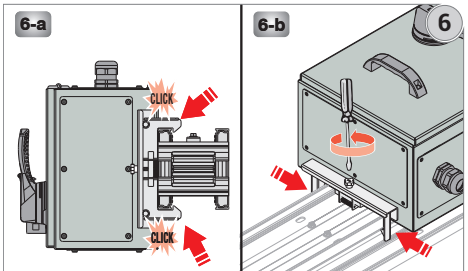

6-Push the box towards the Busbar housing a "click" sound will be heard from the locking parts in the box, ensure the interlock between the box and the housing and thereafter tighten the screw.



During the installation of the tap-off box, if the box body comes to the busbar joint cover, there will be a risk that the contact will not fit properly on the busbar, so either the box installation should be done on a different suitable window or a busbar project revision should be requested. The box body should never be installed in a way that it coincides with the busbar joint point.



#### Important!

Busbar system must be de-energised before mounting or removing a "bolt-on" tap off box. Always use a properly rated voltage sensing device to confirm that the power is off.

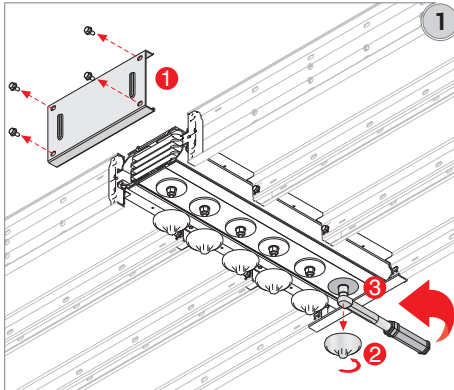

1-Remove the locking pieces. Remove the joint side cover plate and keep the plate and the screws for future use

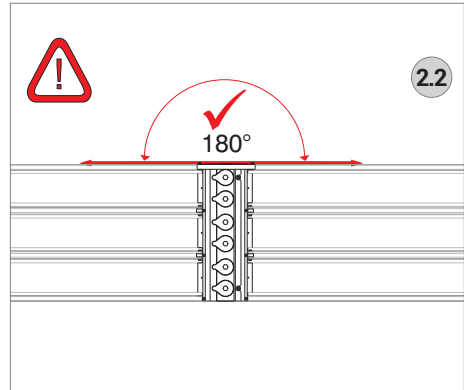
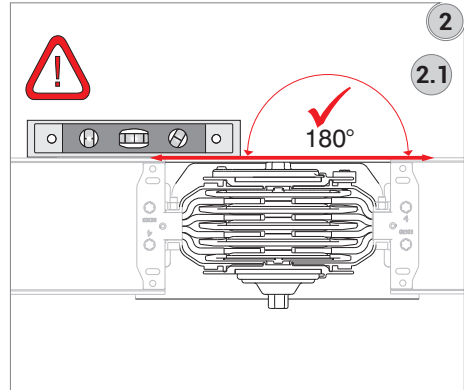

2-Remove the joint cover (1). Remove the locking piece for the nut from the joint where the tap-off box is mounted (2). Loosen the main bolt from nut using a torque wrench (3).

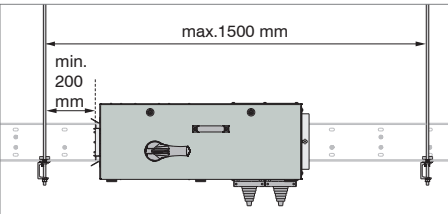

- Do not try to install bolt-on tap-off boxes to plug-in points of the busbar or vice versa.
- Do not try to install 4 wire tap-off boxes to 5 wire busbar or vice versa.

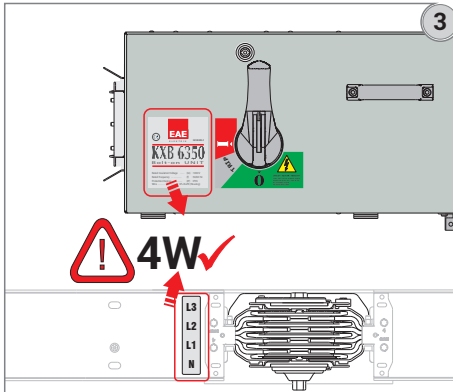

3- Check the phase sequence of the Busbar and tap-off box.

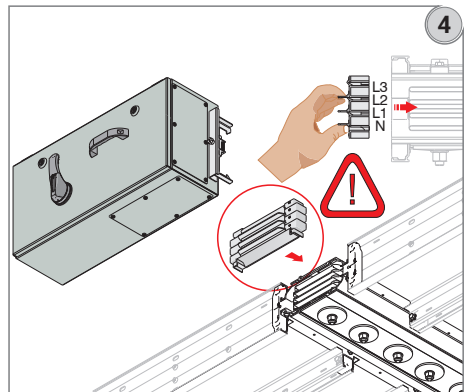

5- Fix the KXB Bolt-on tap-off box to the holes on the Busbar in the correct direction. (Be sure that the breaker's handle is in the off position.)

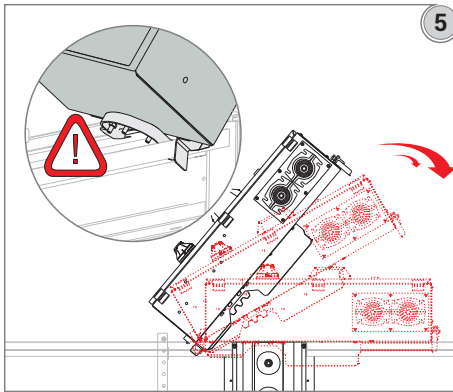

4- Use the alignment plastic piece to fix the joint set. Make sure the direction of the neutral.

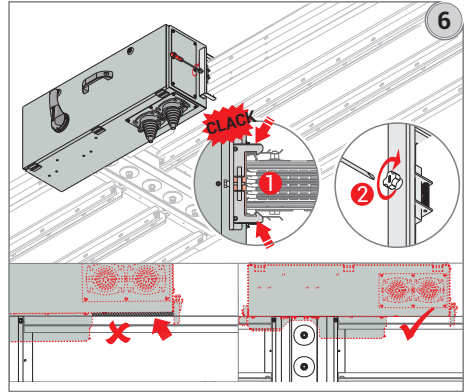

6- Be sure for proper clamping of KXB tap off box's claws (1). Complete assembly by tightening the plastic headed screw (2). Ensure that there is no gap between the Busbar and the tap-off box.

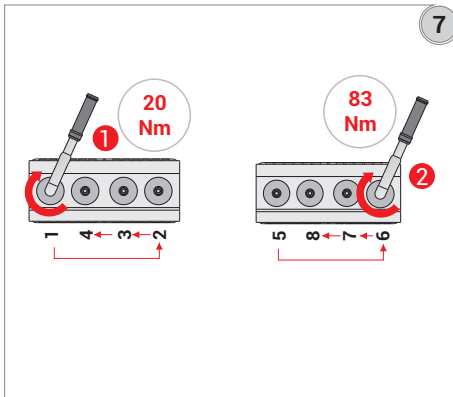

7- If there are more than one bolt for the same phase, bolts shall be tightened by hand to approximately 20-30Nm as per above illustration, then 83Nm shall be applied for the final torque using the same sequence.

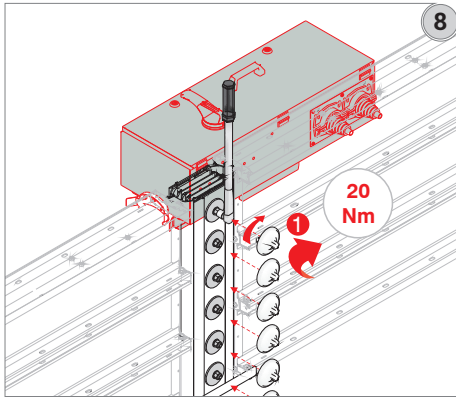

8- Then tighten the locking piece to 20Nm to complete installation(1).

## VERTICAL APPLICATION

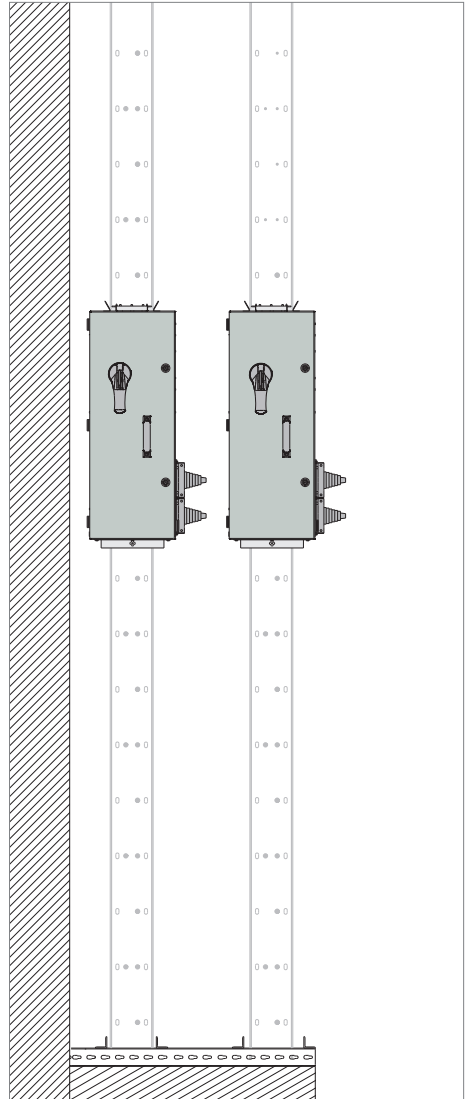

## HORIZONTAL APPLICATIONS

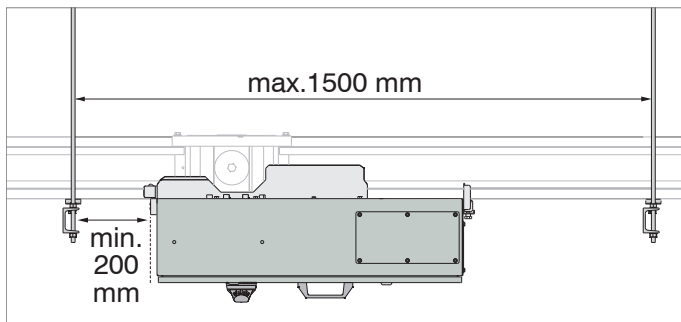
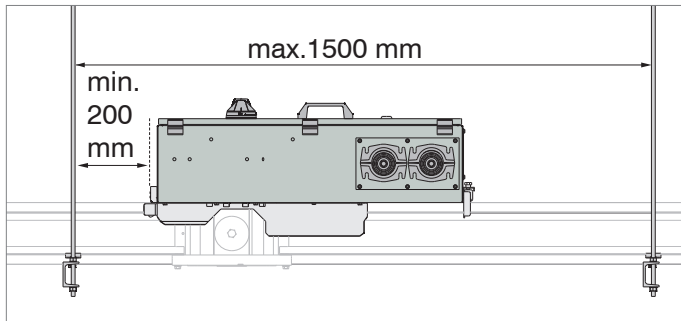
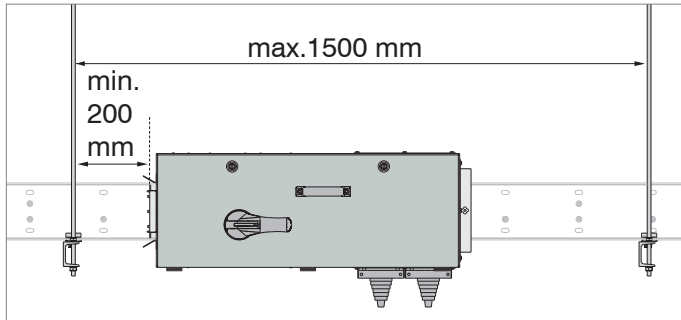

1- When installing the feeder boxes B10, B11 make sure that the phase sequence of the feed box matches the phase sequence of the Busbar. (Care is to be taken to ensure that the neutral is correctly connected).

2- For multi-way Busbars check the position of the matching conductor link, make sure that they are available and fitted correctly. Do not remove these conductor links.

3- Cable glands should be selected according to the size and number of feeder cables. Please consult the factory for requirements other than standard ones supplied

4- Make sure that the incoming feeder cables to the box are all the same length for each phase.

5- Do not cut or drill the feeder units.

## » Installation

### » Flexible Installation to Transformer / Panel

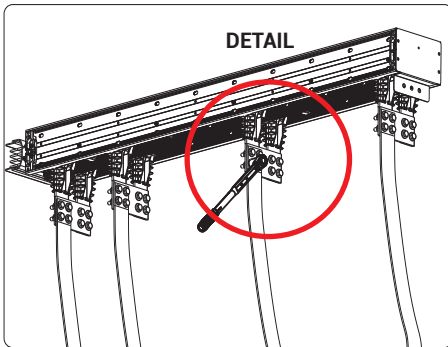

The considerations for flexible installation to transformers or panels are specified as follows:

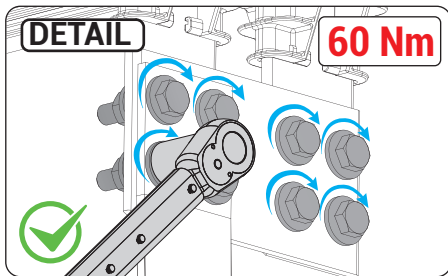

All bolts must be torqued to 60 Nm.

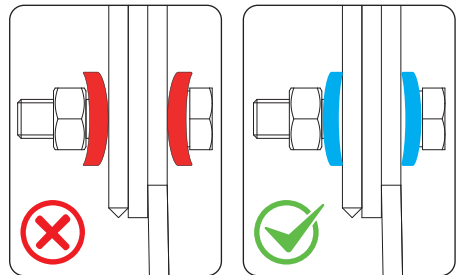

Do not install conical spring washer inverse direction.

**WARNING: HIGH VOLTAGE VALUES CAN CAUSE DEATH OR SERIOUS INJURIES. MAINTENANCE, INSTALLATION AND OBSERVATIONS IN THE CONSEQUENTIAL CONDITIONS; THE ENERGY AND THE CONNECTION MAY BE DONE ON THE BUSBARS CUT OFF AND ELECTRICAL ISOLATED. THEREFORE, ACCIDENTAL CONTACTED CAN BE AVOIDED. FOLLOW ALL MANUFACTURER'S WARNINGS AND INSTRUCTIONS**

1- Make sure that all joint zone connections are correct. Follow the manufacturer's recommended torque settings.

2- Make sure that all bolt-on and plug-in boxes are in the "off" position. Boxes without power must be removed from the Busbar if they cannot be isolated with auxiliary power breakers.

3- Make sure that the connections between the Busbar and the panel, transformer and other connections are interrupted.

4- Resistance testing is to be carried out with a resistance tester of 1000 volts per part of the Busbar to ensure that the system does not contain short circuits and ground faults. (Phase earth, phase-neutral, phase-to-phase). Record the results of the test and provide it to the project manager. Note that the results may vary depending on the Busbar length, width, or number of bars. The results may also vary according to the humidity. If the values are less than 1 MegaOhm / 30 meters, please contact the manufacture

5.1- Before connecting the Busbar to the transformer, panel and other connections, make sure that the phase of the system and the phase of the Busbar overlap.

5.2- Make sure that the ventilation and drainage holes are open. Make sure that the screws and plugs in the drain holes for the outdoor Busbars are removed according to the manufacturer's instructions.

6.1- It is recommended that no energy is applied to the line even if the insulation resistance test successfully completed.

6.2- When the equipment is energized for the first time, qualified electrical personnel must be present. If short circuits and earth faults are present due to damage or poor installation practices are not detected in the exit procedure, serious damage may occur when the power is turned on.

6.3- When the power is supplied, the Busbar must not have an electrical load. Since the Busbar typically runs through several rooms at ground level, care must be taken to see that all devices supplied by the Busbar path are in the "OFF" position.

6.4- The equipment must be energized in sequence starting from the welding end of the system and working towards the load side. In other words, it energizes the main devices, then the feeder devices and then the branch-circuit devices. Turn the devices to the "ON" position with a solid positive motion.

6.5- Once all over current devices have been switched on, loads such as lighting circuits, contactors, heaters and motors can be turned ON.

6.6- When properly used, the Busbar will have a moderate hum. Excessive noise may be an indication of hardware that has not been extruded or incorrectly mounted metal parts.

7- Busbar current, route and hangers should be checked whether they are made according to the relevant isometries.

8- All Busbar system should be checked visually to be certain that they are clean and secure. Loose contaminated connections increase electrical resistance which can cause overheating.

9- Any type of blower or compressed air should not be used to avoid blowing dust into Busbar joints, tap off boxes or circuit breakers. If there is accumulation of dust and dirt, clean it off by using a soft brush, vacuum cleaner, or clean lint free rags.

10- All joints should be correctly tightened according to the torque value given and should be marked. Then install the locking plates correctly. Systems should be checked as per final isometric drawings.

11- I Tap Off boxes fed from the Busbar should be on "OFF" position.

12- The Busbar runs should be isolated by disconnecting all connections to transformers, switchboards, meters, etc.

13- Insulation resistance test using insulation resistance test equipment rated 1000V AC should be conducted to verify the integrity of the system. This test should be performed between phases, neutral and earth. Permanent records should be kept of resistance readings. If the insulation reading appears to be lower than 1 mega-ohm, then the cause should be investigated.

14- The system phase sequence should be checked in order to match the Busbar phases sequence before reconnecting all connections to transformers, switchboards, meters, etc.

## Energizing The Equipment

1- The equipment should be only energized by authorised personnel.

2- There should be no electrical load on the Busbar system when it is energized

3- High voltage in electrical equipment can cause severe personal injury or death. Energizing a Busbar run for the first time is potentially dangerous. Therefore system operational voltage should be checked

4- The connected equipment should be energized in sequence by starting at the source and proceed to end of the system

5- After all over-current devices have been turned on, loads such as lighting, contactors, heaters and motors may be turned "ON".

6- EAE Busbar system are particularly quiet when operating normally. In some installations however there may be a moderate hum. Excessive noise may be an indication of hardware that has not been tightened or of metal parts that have been improperly assembled and this should be checked after de- energizing the system and isolating it safety.

#### **Important!**

Technically, busbar systems do not require maintenance. However, it is recommended to inspect busbar systems annually to identify any conditions that might negatively affect their performance depending on the environmental conditions in which they are used.

During these inspections, the following actions are suggested based on the environmental conditions:

1-Busbar systems should not be exposed to moisture, process vapors and liquid leaks (roof leakage, etc.). In case of any dripping or moisture on the busbar modules, necessary precautions should be taken without delay and the causes should be eliminated. After the relevant checks, this module should be replaced if necessary.

2- There should be no accumulation of dust, soil, mortar, etc., or nests of living creatures (e.g., bird nests) on the busbar systems. If such accumulation is detected, it should be cleaned.

3-Cleaning agents or other materials containing hydrocarbons, which might be used during installation, operation, or maintenance, are not recommended, as they may have harmful effects on plastic component.

4-Thermal imaging cameras can be used to check the temperature of block joints. If any temperature increase is observed, the torque of the connection bolts should be checked. If necessary, they should be re-torqued to 83 Nm as specified in the installation guide.

### **Tap Off Boxes With Protective Devices**

1- EAE tap off boxes are not equipped with any protective device unless they are required by customer. Any type of devices can be fixed in tap off boxes providing specific information about device prior to manufacture in order to adjust interlock mechanism.

2- Tap off boxes operating mechanisms of all electrical & mechanical interlocks should be energized to determine that they operate freely to their full on and off positions.

3- The total continuous load current should be measured by using proper instruments that does not exceed the current rating on the Busbar name plate or the designated design current.

4- After performing all of the above inspections and necessary repairs, it may be desirable to perform an infra-red temperature test on all electrical connections after the Busbar system is re-energized and reaches a stabilized operating temperature.

#### **Important!**

High voltages in electrical equipment can cause severe personal injury or death unless otherwise specified. Installation, inspection and preventive maintenance should only be performed on Busbar system of which the power has been turned off, disconnected and electrically isolated so that no accidental contact can be made with energized parts.

Operation of the Busbar trunking which has been water or moisture damaged can cause property damage, severe personal injury, or death. Observe the precautions to assure adequate insulation resistance and that sources of moisture are eliminated. Latest IEC 61439-6 and locally applicable safety related work practices should be followed at all times.

▶ Junction Resistance Test

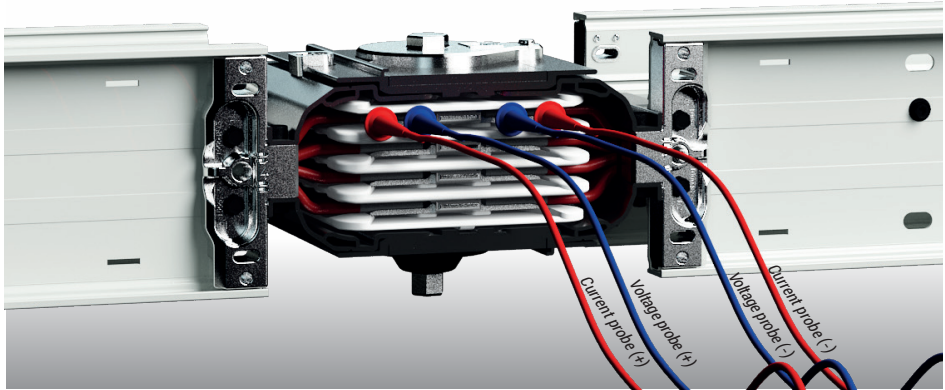

$R_{maks} \leq 15 \mu\Omega$

▶ Line Insulation Resistance Test

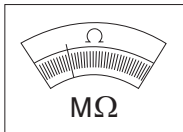
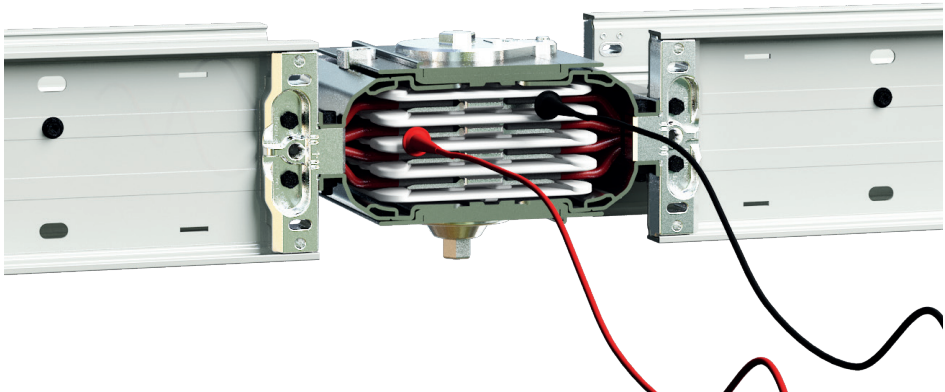

≥ 1MΩ OK  
 < 1MΩ NOT OK

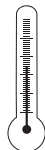

< 5°C → STOP  
 > 35°C → STOP

T(°C)

### PURPOSE

Joint resistance must be measured to ensure contact quality and to prevent the busbar from overheating during operation. The purpose is to measure the joint resistances of KX type of busbars' of EAE branded.

### SCOPE

This test instruction covers KX type of EAE branded busbars whose joint resistance is to be measured. Since the measurement of joint resistance is not defined in the relevant busbar standards, this test instruction has been prepared based on OHM law.

### APPLICATION OF THE TEST

The OHM law is based on a four-wire measurement in this test: a constant current is injected and the resulting voltage drop is used to calculate the resistance.

Joint resistance measurement points for a representative joint connection are given in Figure 1.

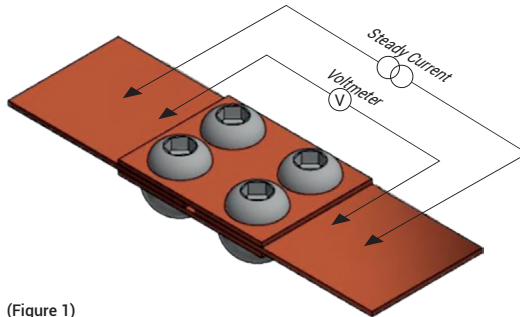

(Figure 1)

The diagram given in Figure 1 is a reference for joint resistance measurement for all kinds of joint connections.

Joint connections may differ in different product types, but basically, measurement in all joint structures is based on the same logic.

Joint structures of EAE busbars of KX model is shown in the drawing below.

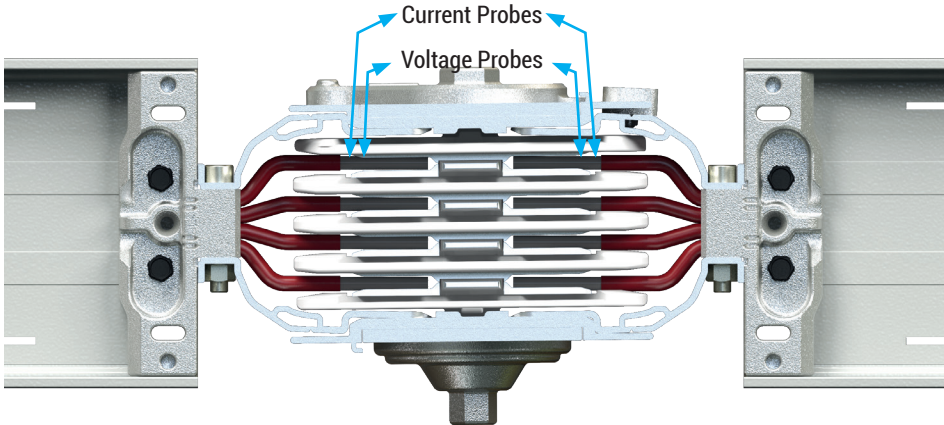

Measurements should be made with a four-wire DC low resistance.

The probes of the device should be connected to the joint structure as shown in Figure 1. A four-wire, calibrated OHM meter that applies at least DC 10 Amperes should be preferred.

The most suitable measuring probes should be used according to the joint structure.

As shown in Figure 1, joint resistance measurements are made after the measurement probes are connected to the joint connection.

Joint transition resistance measurements are repeated at least twice to ensure the measurement result.

The difference in resistance value measured for L1, L2, L3 and N conductors in the same joint can not be more than 10  $\mu\Omega$ .

Joint transition resistance measured for PE conductor can not be more than 100m $\Omega$ .

Maximum joint transition resistance is 25  $\mu\Omega$ . All values below this value are considered acceptable.





EAE Elektrik A.S.  
Head Office  
Akcaburgaz Mahallesi,  
3114. Sokak, No:10 34522  
Esenyurt - Istanbul - TURKEY  
Tel: +90 (212) 866 20 00  
Fax: +90 (212) 886 24 20

EAE DL 3 Factory  
Busbar  
Gebze IV Istanbul Makine ve Sanayicileri  
Organize Bolgesi, 6. Cadde,  
No: 6 41455 Demirciler Koyu,  
Dilovasi – Kocaeli - TURKEY  
Tel: +90 (262) 999 05 55  
Fax: +90 (262) 502 05 69



KX Manual 12-En. / Rev.11 / -- Pcs. / 20.04.2026  
D.S.

EAE has full right to make any revisions or changes on this catalogue without any prior notice.